

Operations Manual

ResMark 5000 High-Resolution System

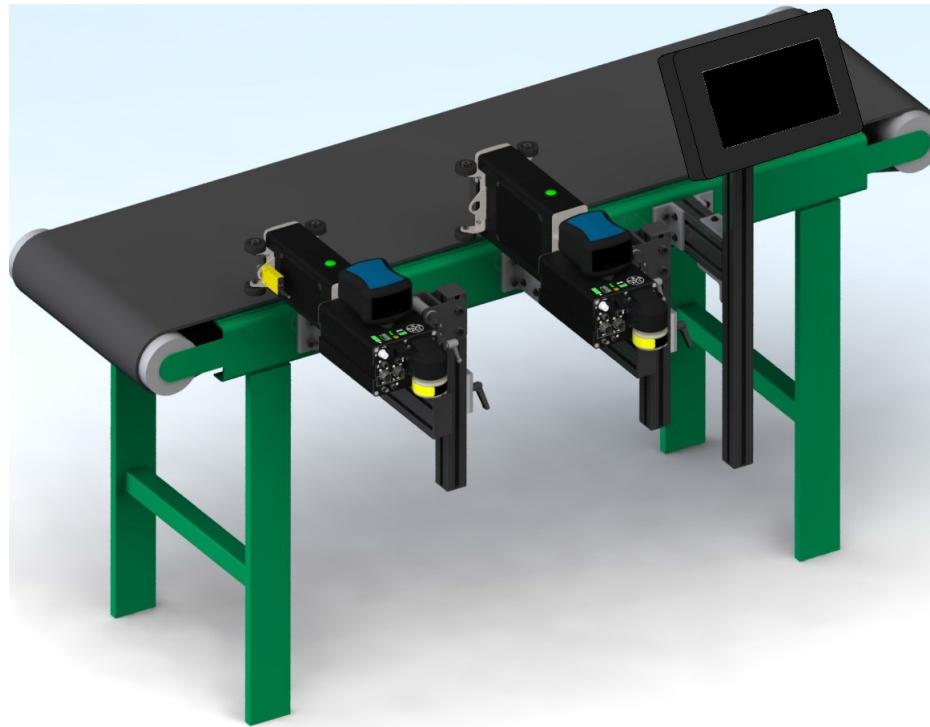

400386
Revision A

ResMark 5000 High-Resolution Ink Jet System Operations Manual

400386

The information contained in this manual is correct and accurate at the time of its publication. ITW reserves the right to change or alter any information or technical specifications at any time and without notice.

©2022 Illinois Tool Works Inc.

All rights reserved

ResMark 5000 System

Warranty:

The ResMark 5000 High-Resolution System, including all components unless otherwise specified, carries a limited warranty.

The inks and conditioners used with the ResMark 5000 High-Resolution System carry a limited warranty.

For all warranty terms and conditions, contact Diagraph, an ITW Company, for a complete copy of the Limited Warranty Statement or visit Diagraph.com.

Section 1: Safety and Ink Usage	6
Section 2: Quick Start	7
Step 1: Assemble Bracketry to Conveyor	8
Step 2: Assemble Print Head onto Bracketry	9
Step 3: Mount and Connect Power Supply	10
Step 4: Powering up the Print Heads	11
Step 5: Adjust Print Head to Substrate	12
Step 6: Print Head Level and Tilt	13
Step 7: Install Ink Cartridge	14
Step 8: Priming the Print Head and Testing Print Quality	15
Step 9: Mount Photosensor and Encoder	16
Step 10: Daisy-Chain Print Heads, HMI, and/or Customer Network	17
Step 11: Cap Unused Ports	19
Step 12: Create a Message and Control the Print System	19
Section 3: Maintenance and Shutdowns	20
System Maintenance	20
Printer Module Maintenance	20
Ink Supply Module Maintenance	21
Printer System Shutdown	21
Cleaning Maintenance System	22
Printer Module Replacement	23
Section 4: Troubleshooting	24
Print Quality	24
System	27
Appendix A: System Specifications	30
System	30
Touch Pro 2 HMI	31
Mark 2 Print Head	32
Mark 4 Print Head	33
System Interconnect Diagram	34
Customer System Connection	35

Appendix B: Theory of Operation	36
Functional Description	36
ResMark 5000 Mark 2 and Mark 4 Print System	36
ISM Features	37
Ink States	38
Print Head Daisy Chain	39
Print Trigger Photosensor	39
Encoder	39
 Appendix C: Diagrams	 40
ResMark 5000 Main CPU PCB Assembly	40
ResMark 5000 Internal Wiring Diagram	41
 Appendix D: Ink	 42
Storage Life of a FACTORY SEALED Bottle of Ink	42
Use Life of an OPENED Cartridge of Ink	42
 Appendix E: Updating the ISM via USB or Ethernet	 42
 Appendix F: Software Interface	 42
 Appendix G: Part Numbers	 43
System	43
Print Head Replacement Parts	44
Bracketry	45
Fittings	46
Cables	46
Service Parts and Optional Equipment	47

Section 1: Safety and Ink Usage

Following is a list of safety symbols and their meanings, which are found throughout this manual. Pay attention to these symbols where they appear in the manual.



Wear safety goggles when performing the procedure described!



Caution or Warning! Denotes possible personal injury and/or damage to the equipment.



Caution or Warning! Denotes possible personal injury and/or equipment damage due to electrical hazard.



NOTE: (Will be followed by a brief comment or explanation.)

CAUTION: The Ink Supply Module contains hazardous voltage (90VDC). Disconnect from mains power before:

- Performing preventive maintenance.
- Performing any repairs to the unit.
- Servicing the equipment in any manner.



ESD protection should be worn when servicing internal printed circuit boards.

After service to the equipment is completed, replace all protective devices such as grounding cables and covers before operating the equipment.

It is extremely important to:



- Clean up all spills and dispose of all waste according to local and state regulations.
- Wear safety glasses and protective clothing, including gloves, when handling all inks and conditioners.
- Store inks and conditioners under the recommended conditions found on the SDS (Safety Data Sheet).



Service is to be performed by trained or ITW personnel only.



Caution: Denotes possible personal injury due to sharp object.

Section 2: Quick Start

The figure at right illustrates a typical installation.

System Components:

1. Bracketry Kit (Item 1)
2. Print Head (Item 2)
3. HMI (Item 3)
4. Power Supply (Item 4)
5. Photosensor (Item 5)
6. Encoder (Item 6)
7. Power Cord (not shown)
8. Ethernet Cable (not shown)
9. Software (not shown)
10. Ink (not included)

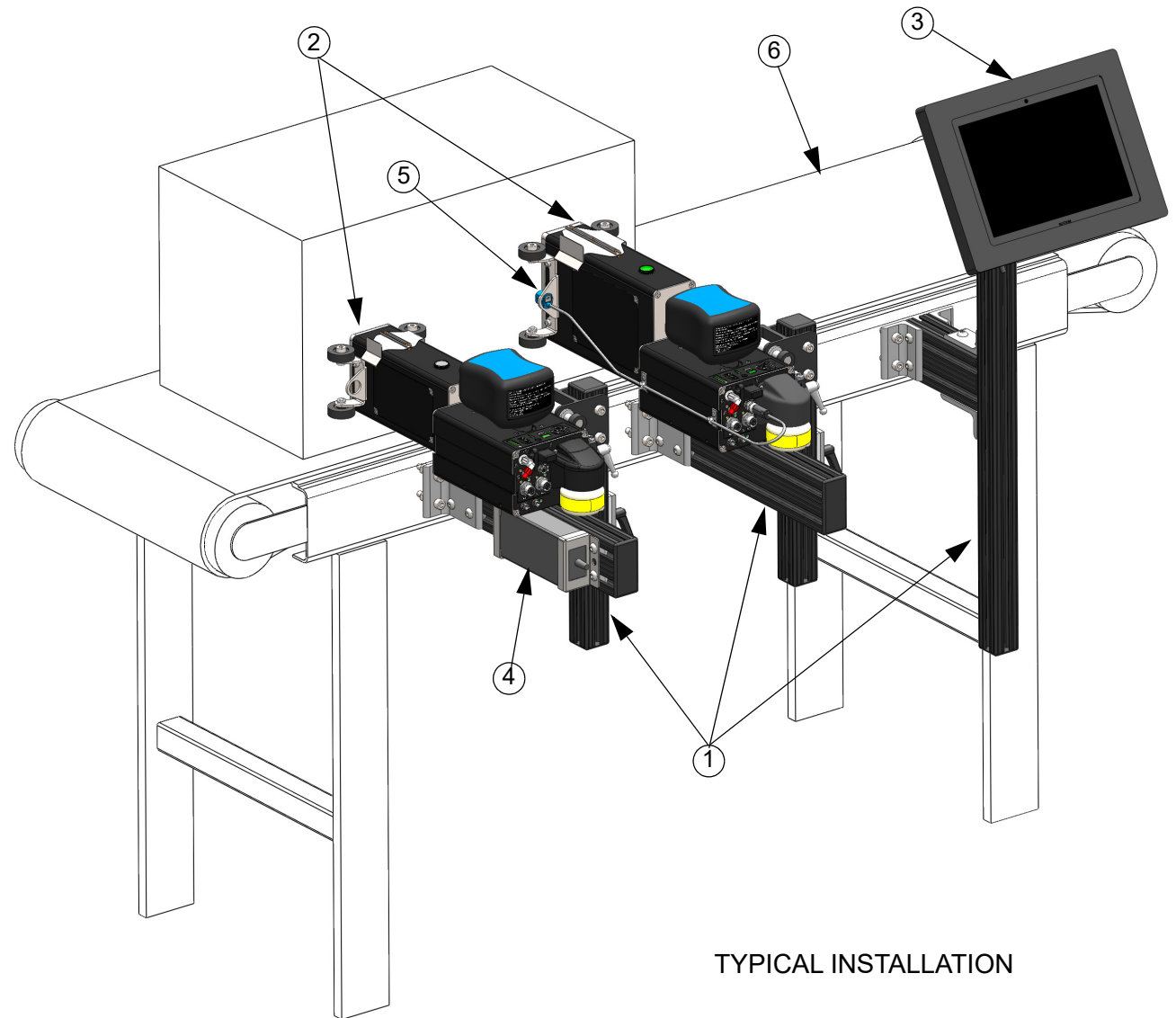

TYPICAL INSTALLATION

Step 1: Assemble Bracketry to Conveyor

1. Firmly tighten all fasteners.



NOTE: Ensure bracketry is square and level.

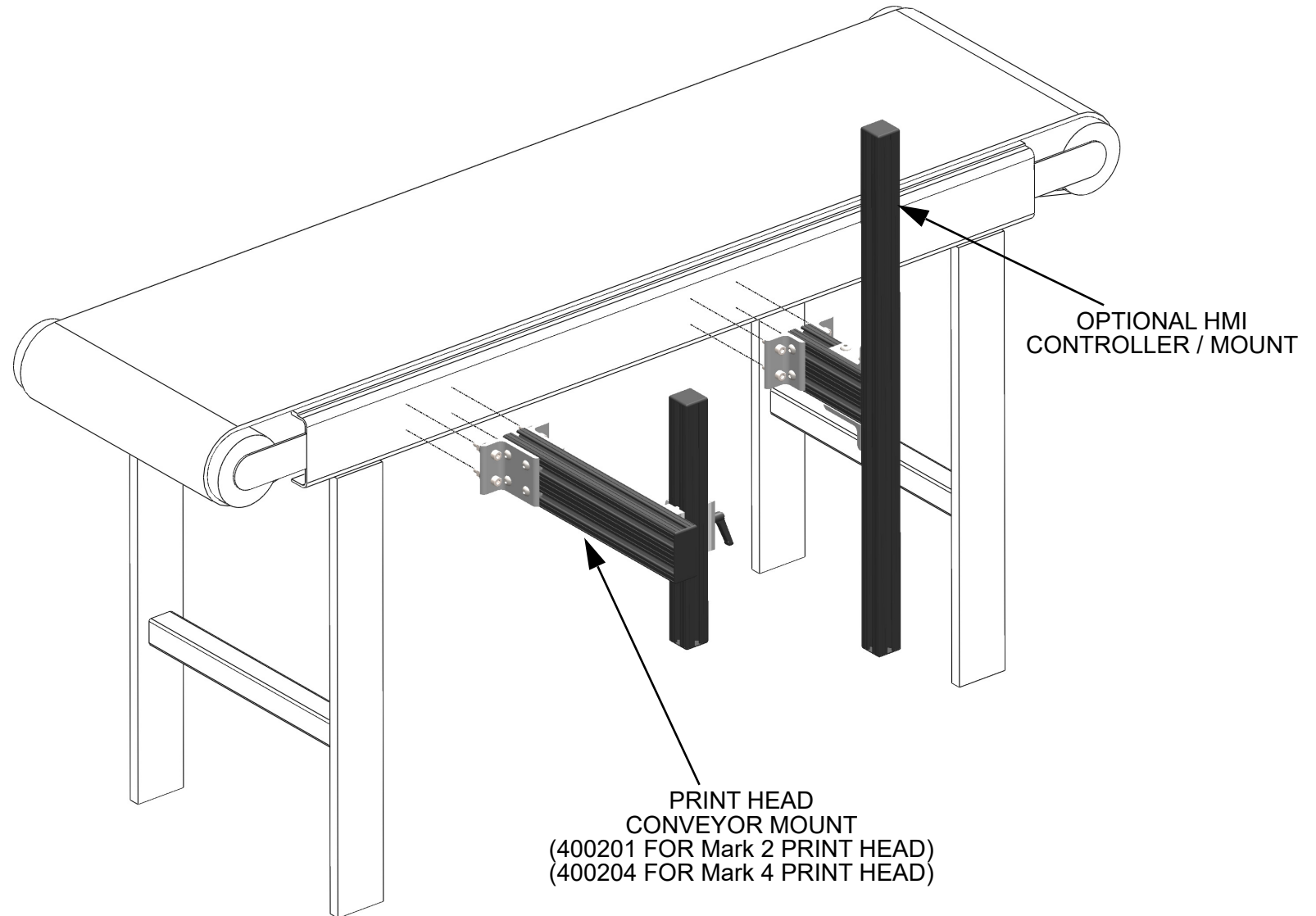

Step 2: Assemble Print Head onto Bracketry



NOTE: The dovetail adapter and mounting bracketry can be mounted on either side of the print head system.

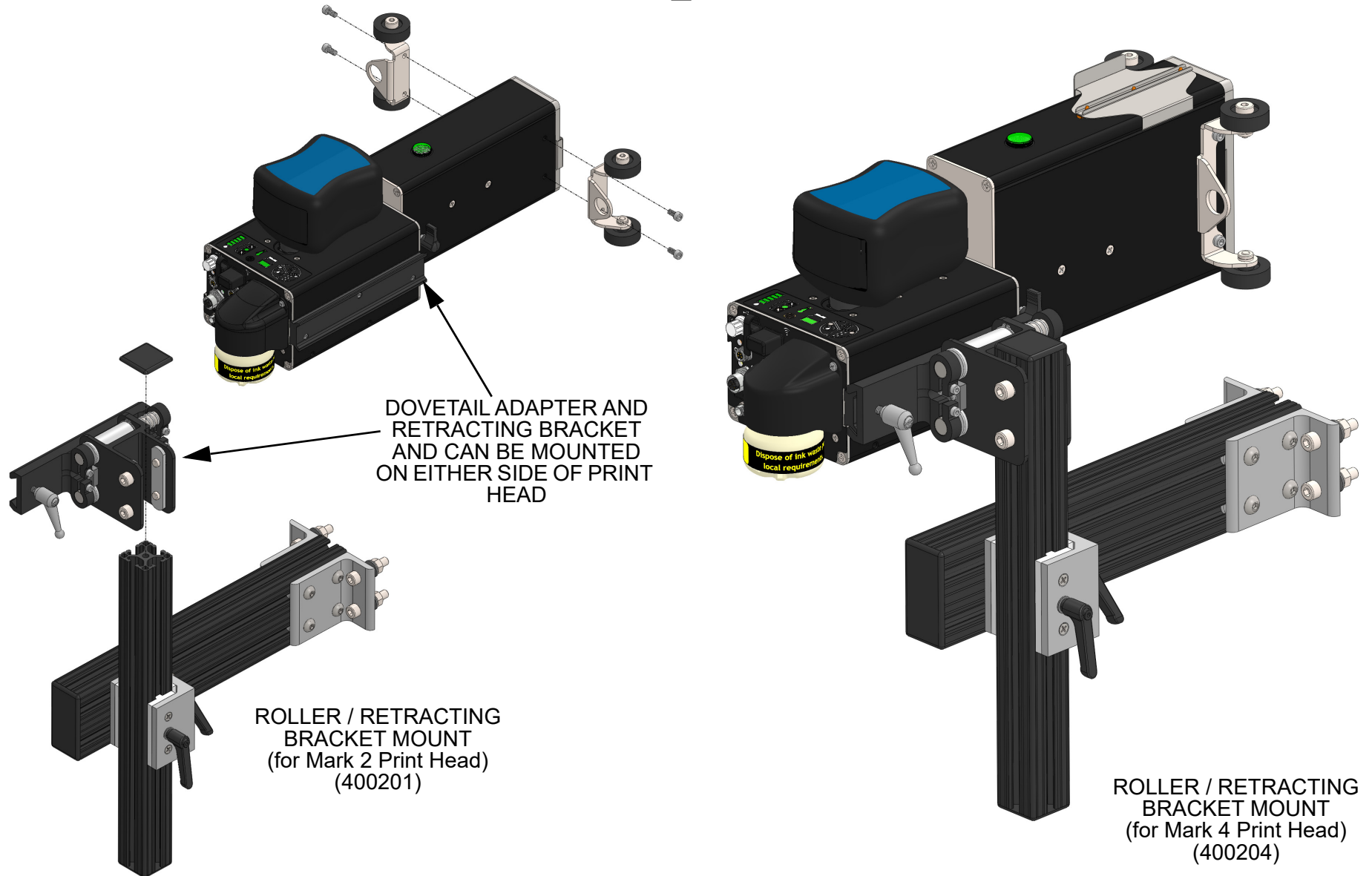

Step 3: Mount and Connect Power Supply

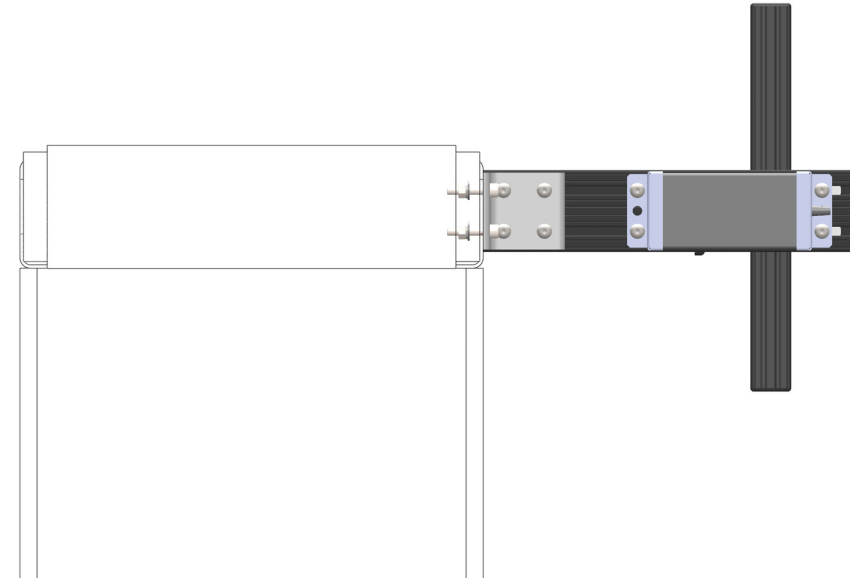
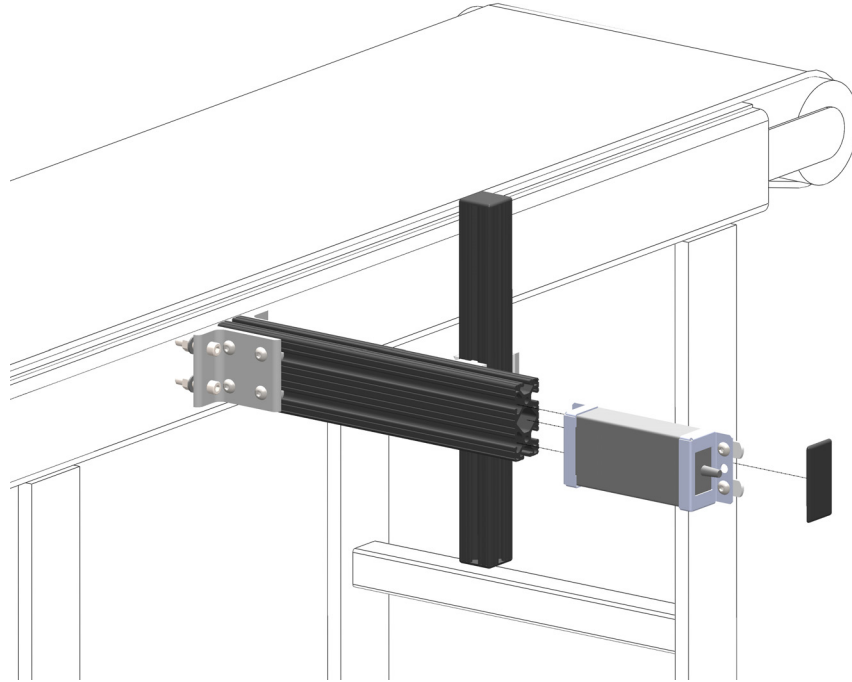

1. Install power supply with power cord mains facing the conveyor and DC output facing out towards the rear of the print system.
2. Firmly tighten fasteners to bracketry or convenient location.



NOTE: One power supply pack can power up to two print heads in any combination of Mark 2 or Mark 4.

Step 4: Powering up the Print Heads

1. Install the power cord into the first print head in the system (from now on called the Primary print head).



**The power supply cable or jumper cable can be plugged into either power port.
Do not over-tighten with pliers.**

2. If there is more than one print head, the Primary should be the print head to have product pass by it first; therefore, it should have the photocell mounted to it on the leading edge.
3. Ensure the power connector is fully inserted and the threaded barrel is finger tight.
4. Connect any downstream print heads from the Primary. These are considered Secondary.
5. Only one Secondary print head can be powered by an upstream print head. An additional power supply will be required for every two print heads on a daisy chain, regardless of print head type / size.
6. Plug the A/C cord into the mains.



Best practices are to plug power into the print heads first before the A/C mains.

TYPICAL INSTALLATION

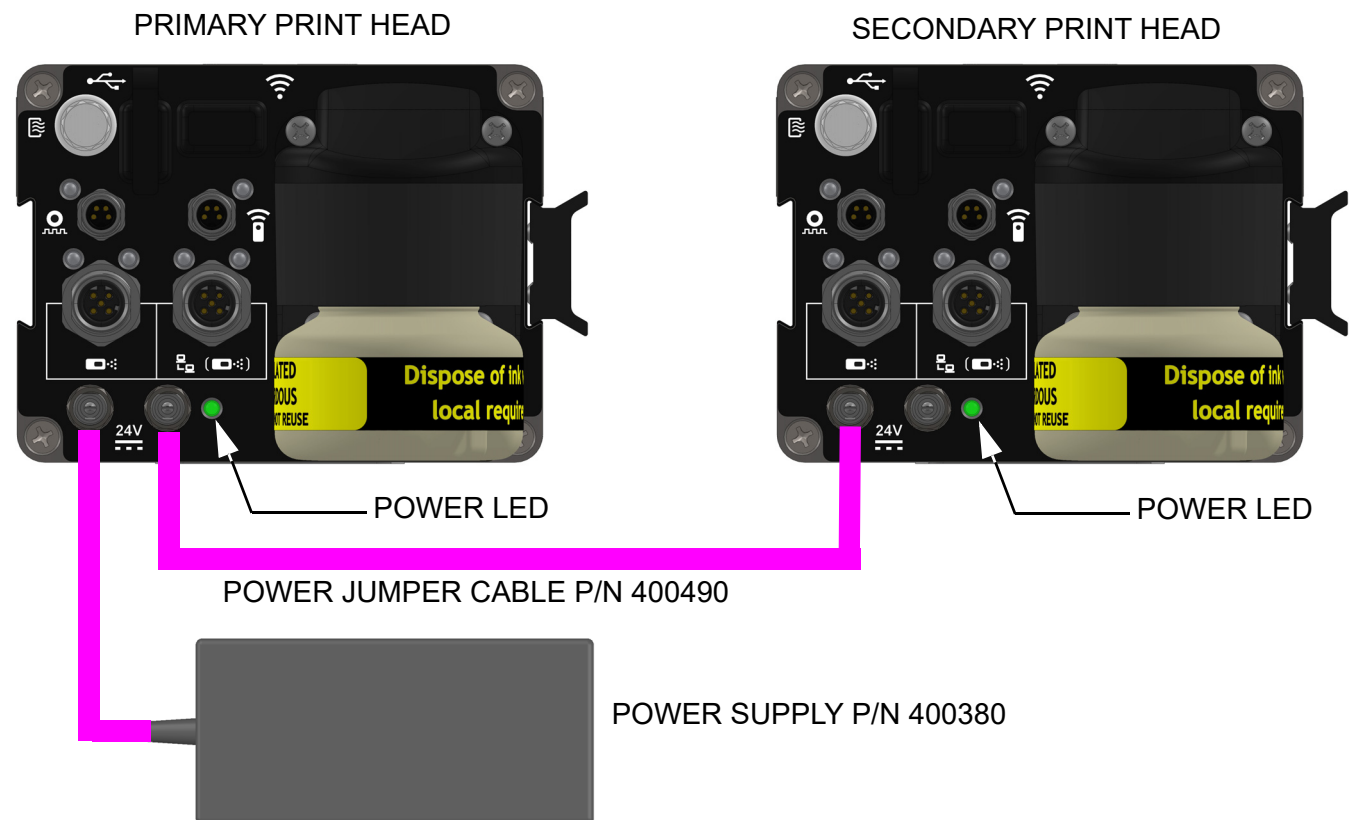

Step 5: Adjust Print Head to Substrate

1. Tighten bracketry to conveyor such that the print head is perpendicular to the carton; however, ensuring that the print head is level from front to back. See “Step 6: Print Head Level and Tilt” on page 13.
2. Use vertical tool-less handles to adjust print head to approximate printing height position. Tighten handles.
3. While horizontal adjustment slide bracketry screws are loose, adjust vertical bracket with print head horizontally to within 6 mm (1/4 in) of the carton.
4. Use the dovetail tool-less handle to make fine adjustments between the print head rollers and carton to within 1 mm - 2 mm (.04in - .08 in).



NOTE: Print head print gap can be adjusted to be larger in heavy debris environment but must be balanced with print quality.

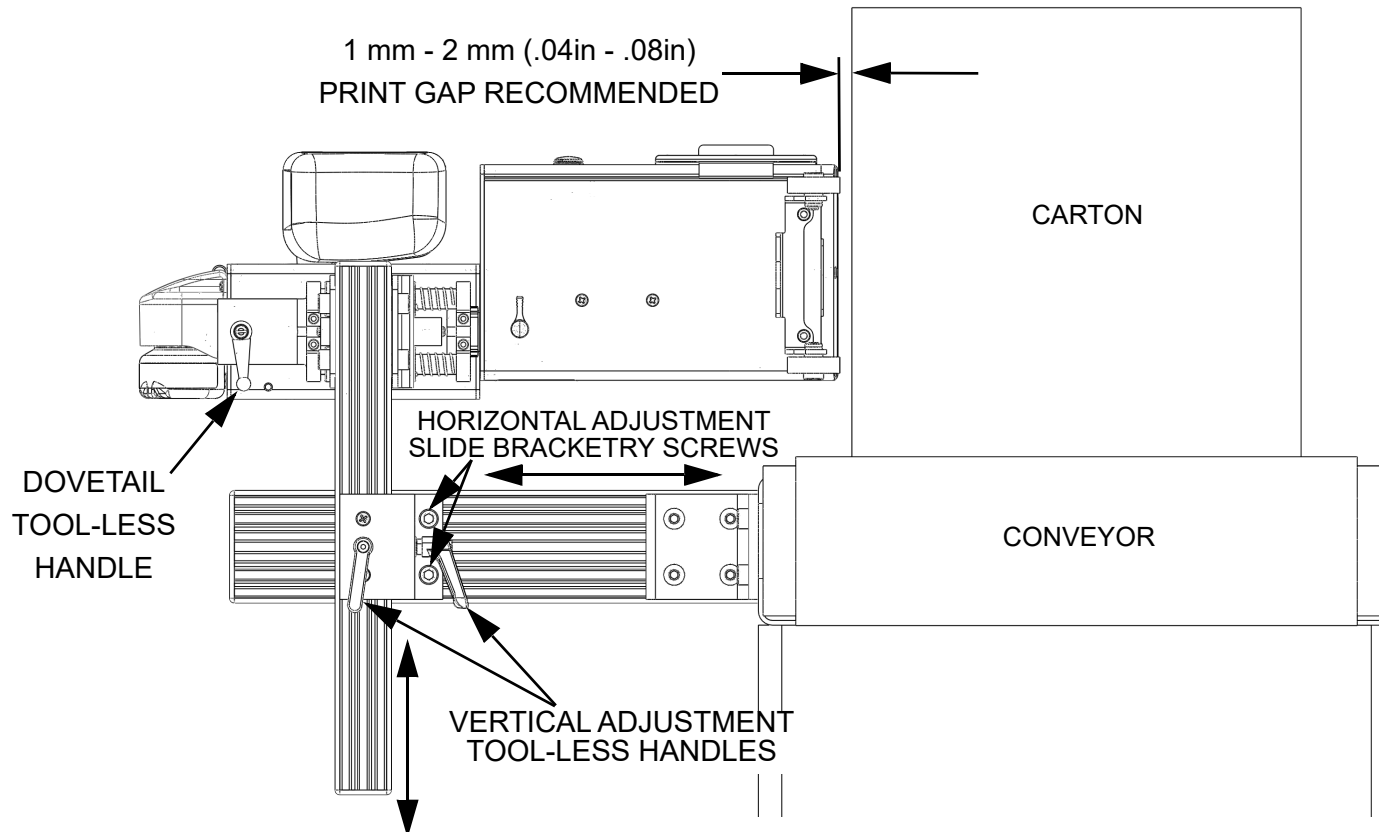
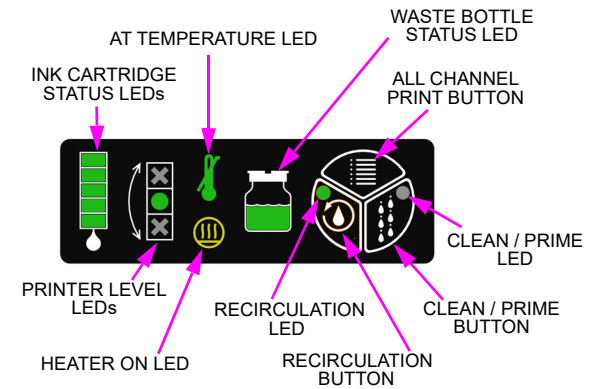

Step 6: Print Head Level and Tilt

Print Head Level

1. Slightly loosen the Slide Bracketry Screws shown in the diagram in “Step 5: Adjust Print Head to Substrate” on page 12.
2. When the print head is perpendicular to the substrate, tighten the Slide Bracketry Screws.
3. Observe the LED indicators on the rear top of the print head on the ink supply. The green LED should be illuminated, and if not, adjust the bracketry up or down as needed.
4. The print head is calibrated to within $\pm 1.5^\circ$



Print Head Level



Print Head Not Level

Print Head Tilt

1. Loosen the tool-less handle on the side of the Printer Module.
2. Rotate the Printer Module to an angle that creates perpendicular print on the product.
3. Tighten the tool-less handle.

Maximum Print Head Tilt from Vertical When Viewed from the Rear of the Print Head:

- Clockwise Tilt: 85° (Printer Module disengages from the Ink Supply Module at 90°)
- Counterclockwise Tilt: 90°

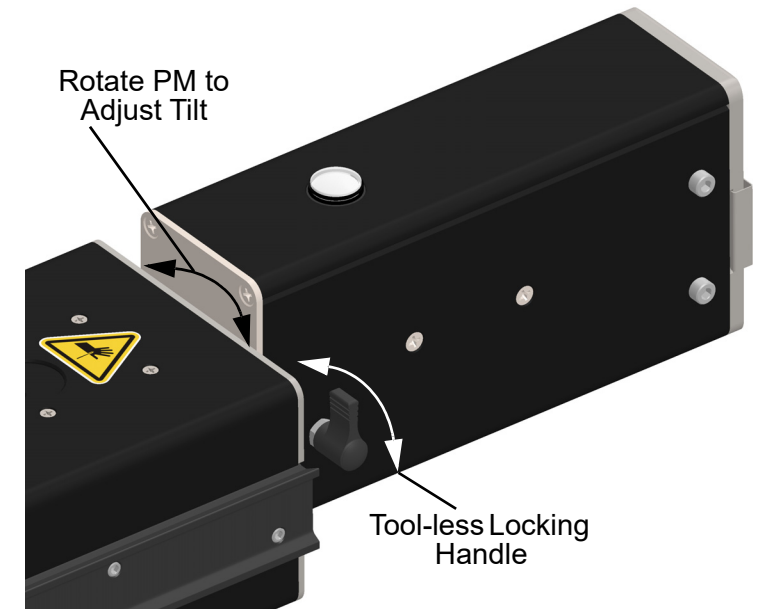
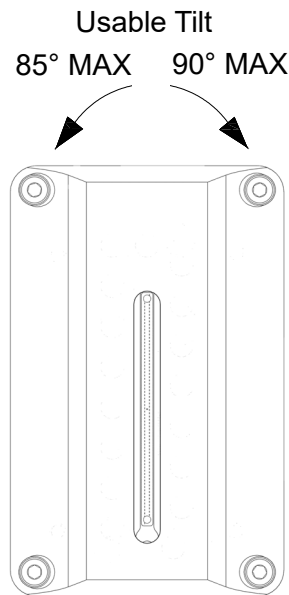

Cleaning and priming features are effective up to $\pm 15^\circ$

Step 7: Install Ink Cartridge

1. Remove the shipping plugs from the rear and top of the Ink Supply Module. Retain plugs for potential later use.
2. Install the ink cartridge and vent filter as shown.



Warning! Opening the cartridge door exposes sharp needles used to puncture the cartridge rubber seal. Extreme caution should be used during the cartridge insertion.

3. Install the cartridge in the orientation shown with safety information label facing towards the rear of the print head.



Note: The cartridge is equipped with smart chip technology that will detect the presence of the cartridge. The cartridge can only be installed in one orientation as it is keyed to the Ink Supply receiver which will guarantee connection to the smart chip.

When the cartridge is installed, the state of the ink gauge LED indicators on the top of the Ink Supply and the LED on the top of the Printer Module will change from flashing to solid green as shown below.

For a full description of the LED / Button panel on the top of the of Ink Supply Module see “Ink States” on page 38.

Flashing



Solid

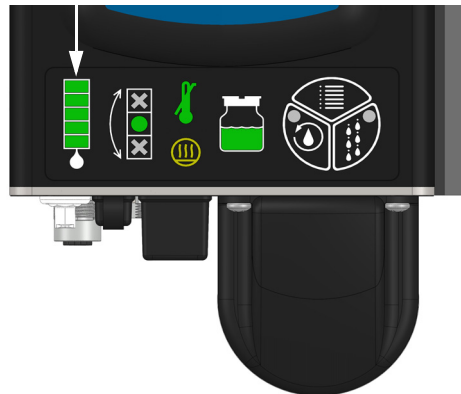

REMOVE

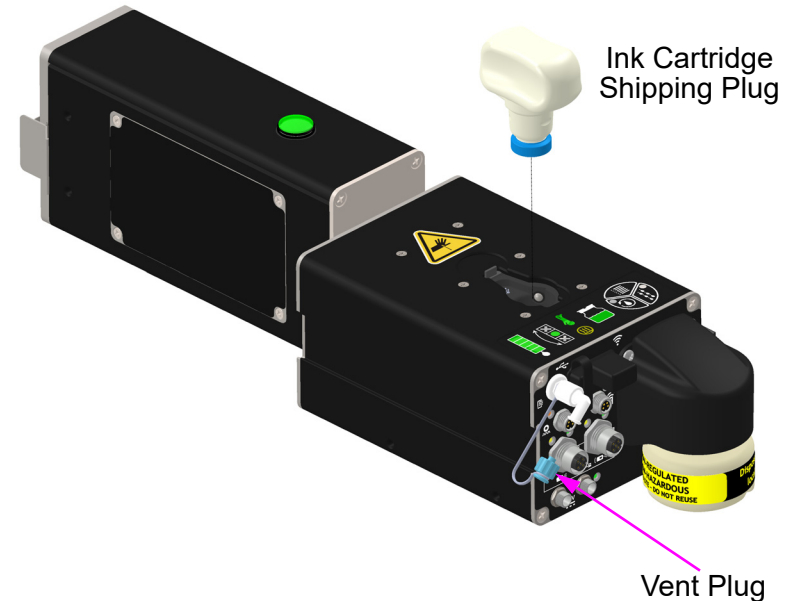

INSTALL

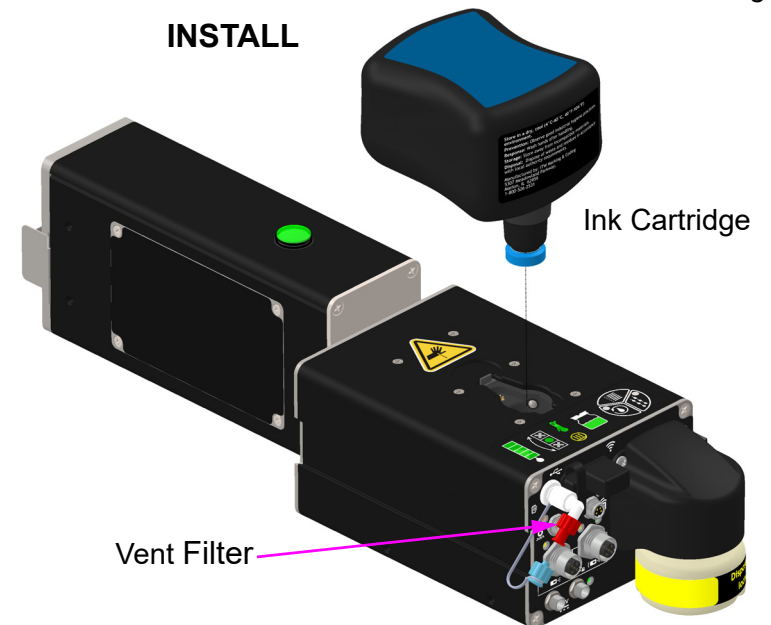

Step 8: Priming the Print Head and Testing Print Quality

1. Ensure all print heads are at operating temperature.
2. Ensure that the shipping cap is installed for priming, otherwise ink will overflow and cause a mess.



NOTE: Print is disabled until the print head is fully heated. Wait until the "AT-TEMPERATURE" LED is illuminated green on the rear of the print head prior to any print sampling.

3. Press and hold the Recirculation button (10 seconds) on the rear top of the ISM until its LED turns on. The ink gauge will count up during this time.
4. Allow the print head to recirculate for at least 2 minutes. To turn off the recirculation feature, press the Recirculation button once, and the LED will turn off. After 15 minutes, the recirculation feature will automatically turn off.
5. Wait three seconds and remove the ship cap and store on the top of the print head.



NOTE: Do not use common wipes in the print channel; use foam swabs instead.

6. Use a foam swab to **lightly** wipe the orifice plate in a vertical downward motion. Prime the print head by pressing and holding the **Clean / Prime** button up to 5 seconds. The Clean / Prime button LED will illuminate during this time and print will be disabled. After an additional 5 seconds, the LED will turn off and print will be re-enabled.
7. Print can be tested by slowly passing a sheet of paper in front of the print head after pressing the All Channel Print button. A solid image will print for approximately 3 seconds.
8. If the Mark 2 sample is 50,8 mm (2 in) tall with no gaps, the print head is ready.
If the Mark 4 sample is 101,6 mm (4 in) tall with no gaps, the print head is ready.

Missing Print

1. Press and hold the **Clean / Prime** button for five (5) seconds.
2. Inspect for very small air bubbles flowing out of the top of the orifice plate. If bubbles are evident, repeat the previous step. one more time.
3. Press the **All Channel Print** button on the rear of the print head.
4. If any print is still missing after all air bubbles are purged, clean the orifice plate and ship cap seal with a clean foam swab, and then recap the print head with the ship cap.
5. Repeat the above steps up to three more times as necessary (starting at step 1). When stubborn channels are present, allow the Recirculation system to run for the full 15 minutes.

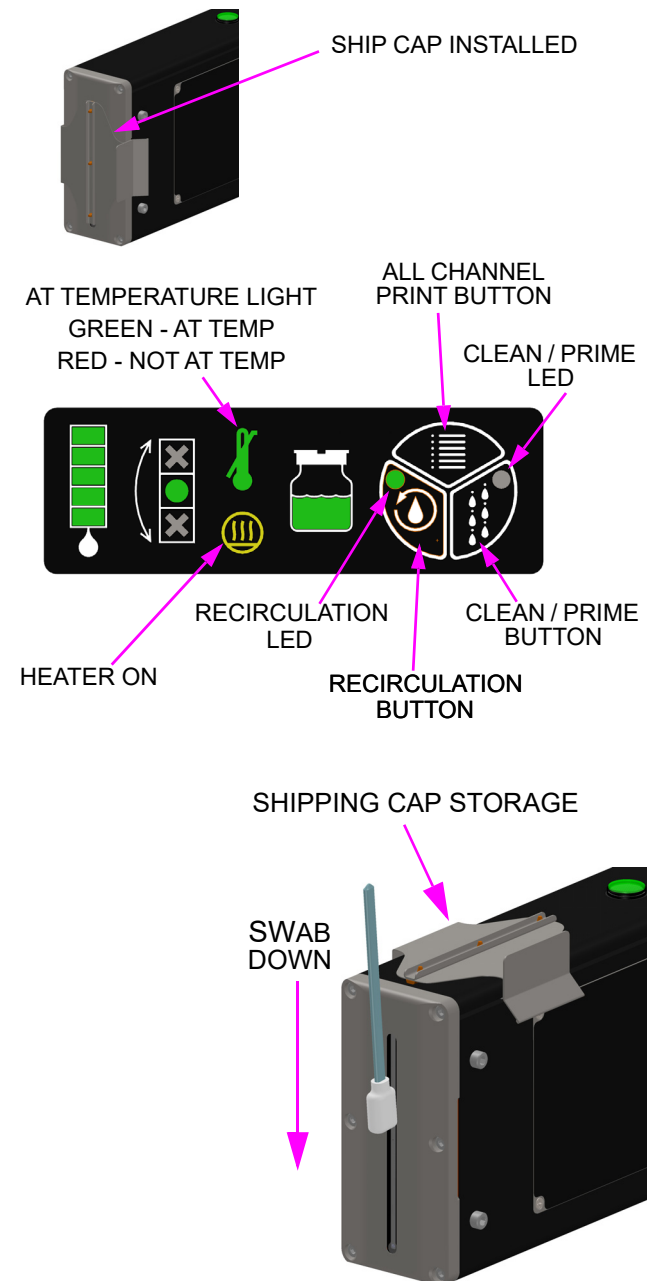

Step 9: Mount Photosensor and Encoder

Photosensor

1. Mount the photosensor (kit 400203) in the roller bracket attached to the Printer Module and route the cable as shown in one of the two shown configurations depending on the application.
2. Insert the photosensor cable connector into the appropriate connector on the rear of the Primary print head Ink Supply Module.

Encoder

1. Install the encoder (kit 400504) in a location where it will accurately measure the speed of the conveyor.
2. Install it in contact with the conveyor belt or with a roller moving the same speed as the conveyor.
3. Insert the encoder cable into the Primary print head Ink Supply Module.

CAUTION: Do not excessively pre-load the encoder wheel. A radial force of over 18,14 kg [40 lbs] will reduce the life of the bearings.

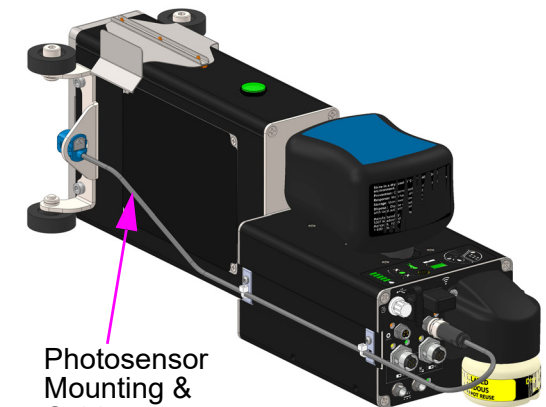

Photosensor Mounting & Cable Routing

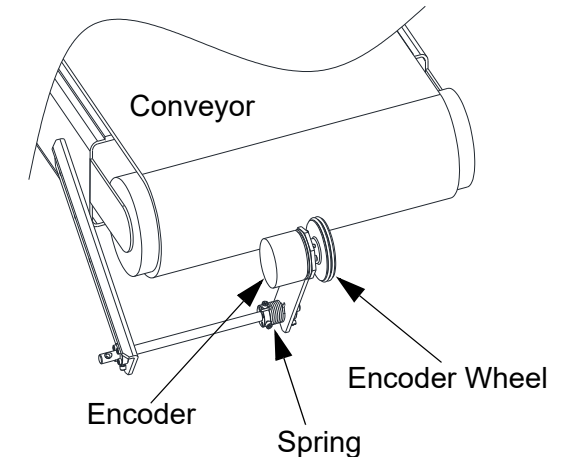
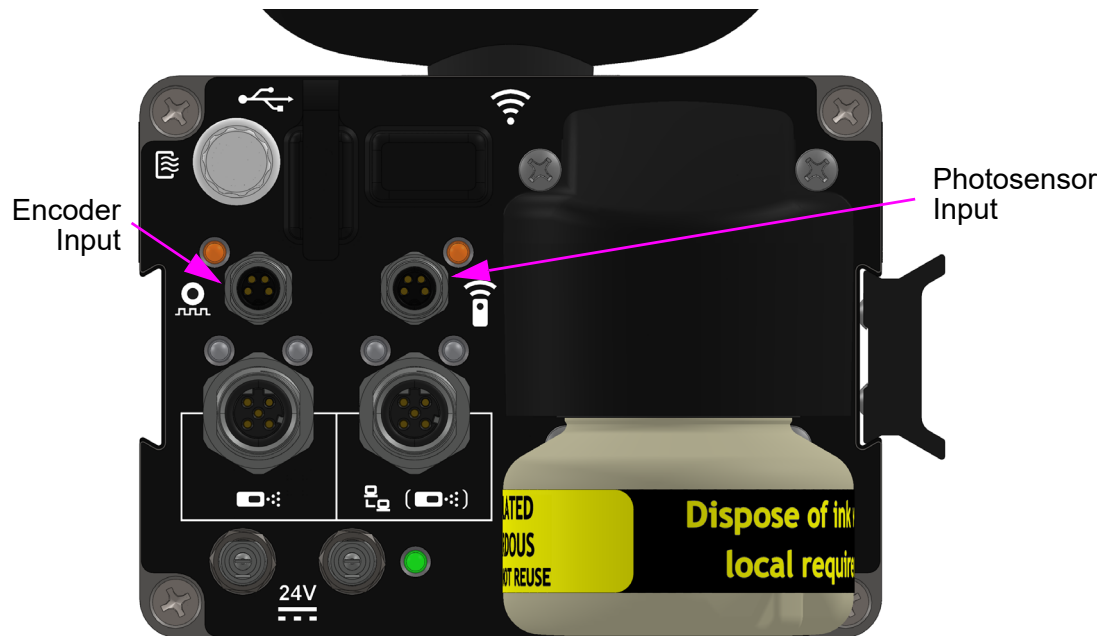
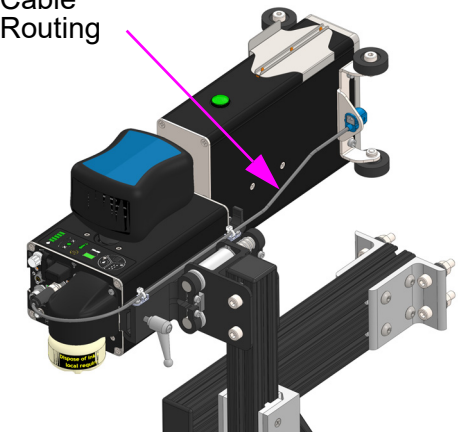

Step 10: Daisy-Chain Print Heads, HMI, and/or Customer Network

1. Install secondary print heads as shown in the previous steps.
2. Secondary print heads should be connected between the upstream print head Ethernet out port to the input port on its print head as shown as shown in the diagrams below. Up to eight print heads can be daisy chained together.
3. Install the HMI / Controller on appropriate bracketry.
4. Connect the HMI or Laptop / PC via Ethernet cable (400374-2.0) as shown in the below diagrams.



NOTE: Alternatively, the Primary print head can be connected to the HMI via wireless. Consult the create and control manual (400463).

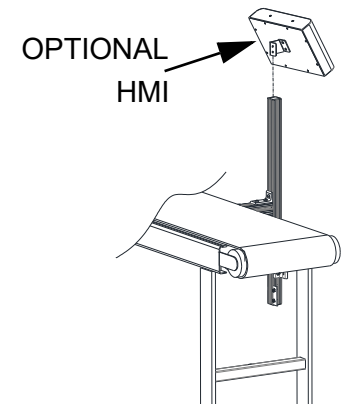

Standalone System with HMI - One Print Head

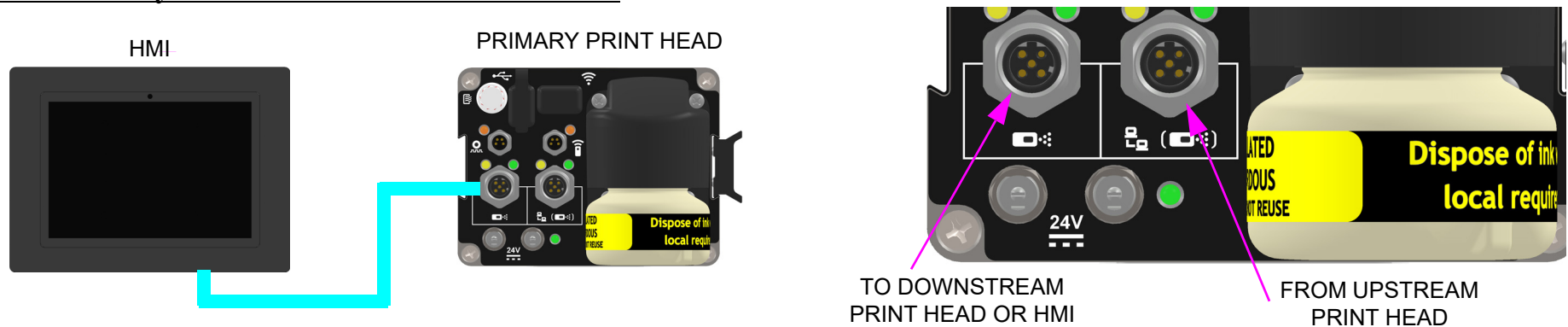

Standalone System with HMI - Two or More Print Heads

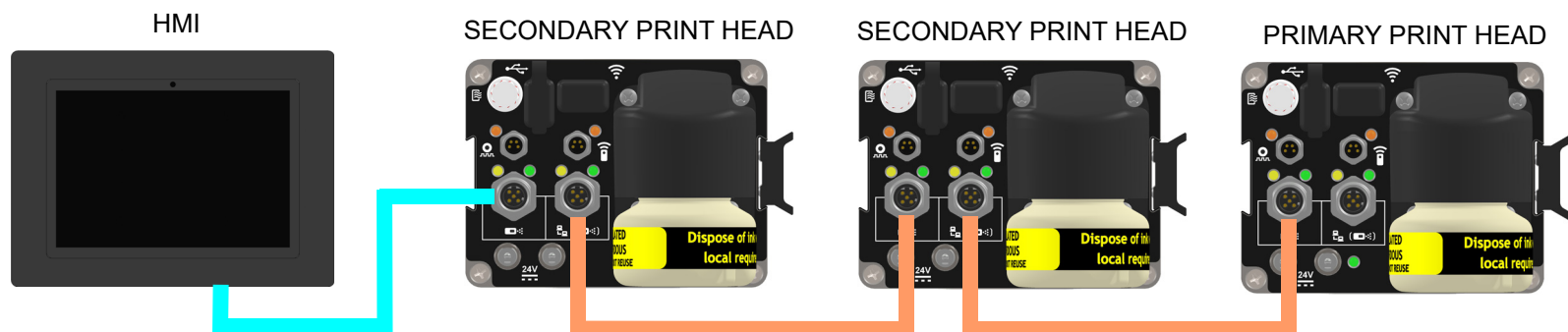

Networked System with Optional HMI - One Print Head

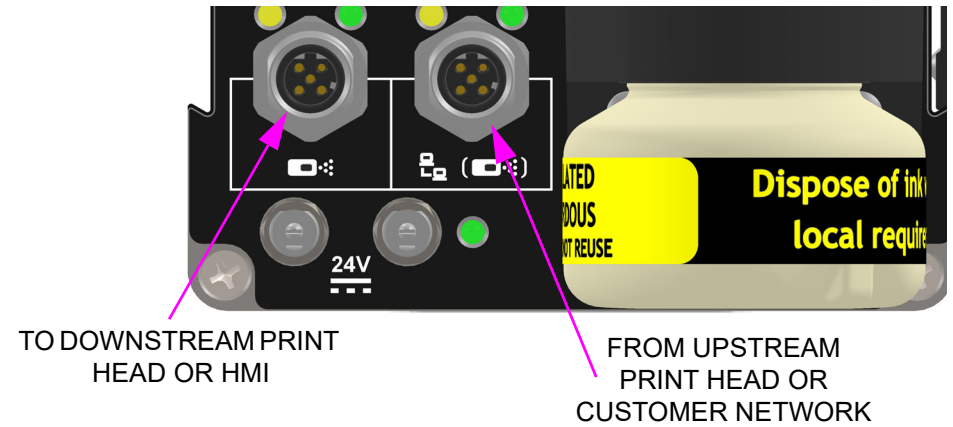
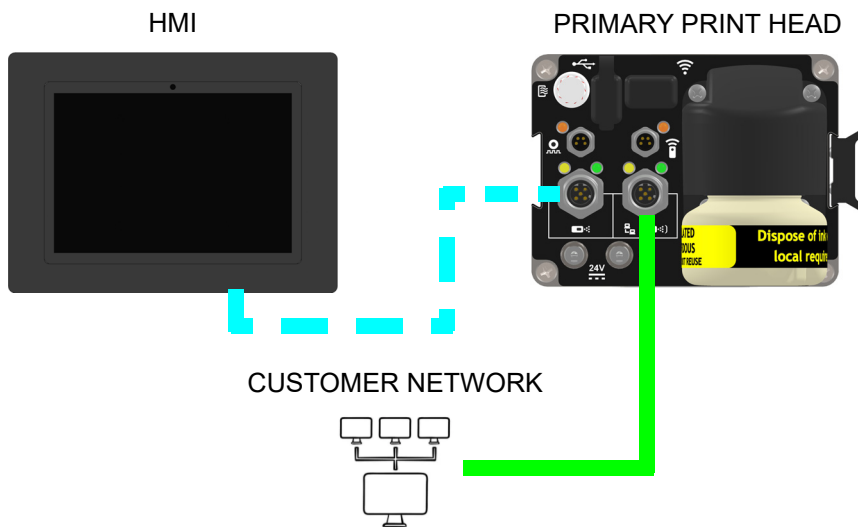

Networked System with Optional HMI - Two or More Print Heads

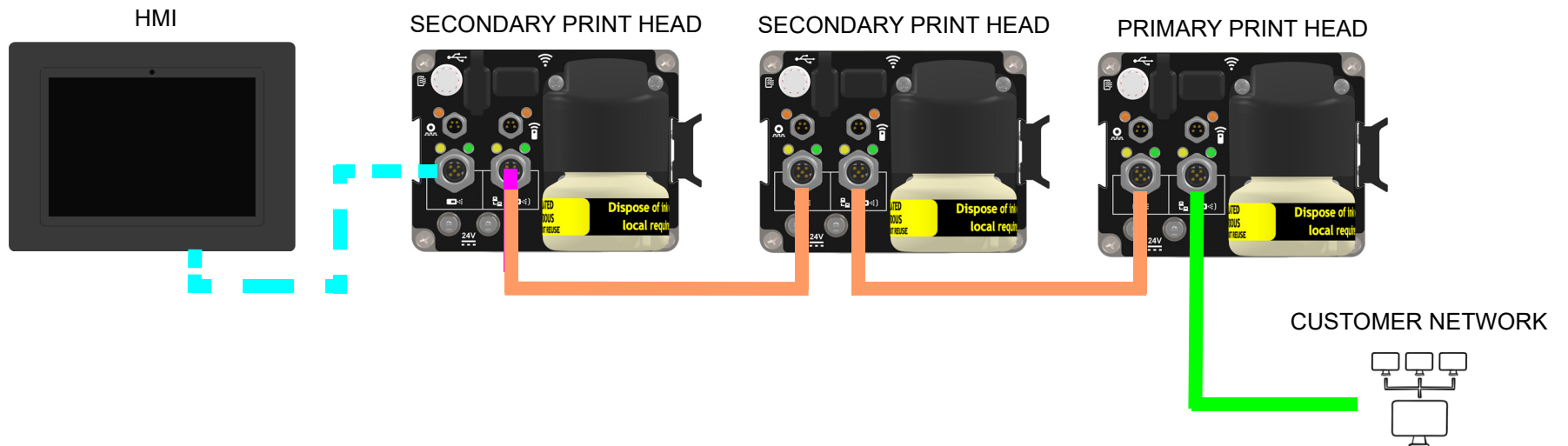

Step 11: Cap Unused Ports



After the installation is complete, it is recommended that all unused ports be capped to prevent accidental electrostatic discharge into a connector.

The Primary print head should have all ports populated with a cable.

Exceptions:

- Only one head in the daisy chain - cap Ethernet and one power port.
- No encoder - cap encoder port.
- Wireless communication - cap Ethernet ports.
- No HMI - cap Ethernet port.

Secondary print heads will have most ports capped excluding one power port.

Exceptions:

- Wired Ethernet port - cap other Ethernet port.
- Second power port is connected to HMI.

See “Service Parts and Optional Equipment” on page 47 for plug and cap kits.

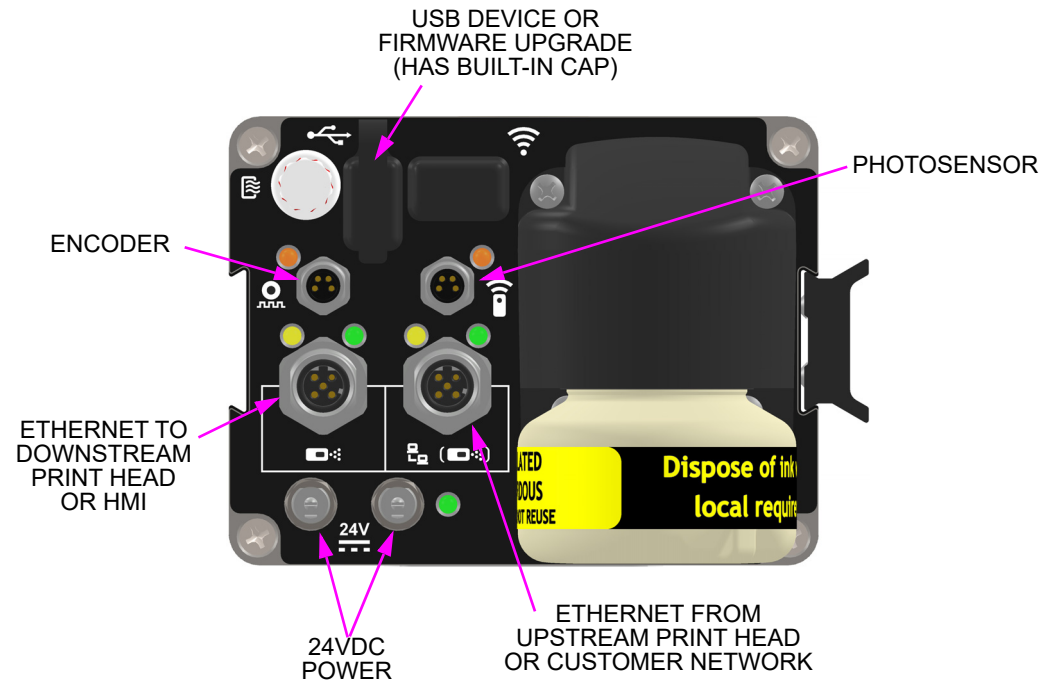

Step 12: Create a Message and Control the Print System

Reference manual **Create & Control 400463**.

Section 3: Maintenance and Shutdowns

Following are the recommended maintenance procedures to keep the ResMark 5000 High-Resolution system printing cleanly and efficiently.

System Maintenance

Intermittent (as required):

1. Be sure the photosensor is clean and free of debris.
2. Be sure the nuts and bolts holding the bracketry in place remain tight.
3. Ensure all cable connections are secure but not overtightened.
4. Adjust Printer Module level and throw distance as necessary.

Annually:

Clean the encoder and review the wheel for excess wear.

Printer Module Maintenance

Daily / Shift Startup / Periodic



Wear safety goggles when working with industrial inks or solutions!

The majority of print quality degradation is due to excessive debris deposits on the print head orifice plate that disrupt the ink droplet path. For best preventative maintenance practices, do the following:

1. Remove excessive debris build-up (corrugate dust, glue strands, and the like) on and around the front of the print head by using maintenance spray (5760695) on a clean lint-free cloth (6600171) and wiping the front plate and enclosure. If debris build-up is noted on the enclosure and rear of the print head, then wipe those clean too.



NOTE: DO NOT SPRAY MAINTENANCE SPRAY DIRECTLY ON THE PRINTER MODULE OR ANYWHERE NEAR THE ORIFICE PLATE.

2. Using a sponge swab (5760832), rub the orifice plate **lightly** from top down in a vertical direction while ink is flowing during a clean cycle. The **Clean / Prime** button is located on the rear of the print head. **DO NOT USE** n-Propanol directly on the orifice plate.
3. Press the **Clean / Prime** button one more time to ensure channel priming, but do not swab this time.
4. Wipe the front plate with a clean lint-free cloth to remove any excess ink.

SHIPPING CAP STORAGE

SWAB
DOWN

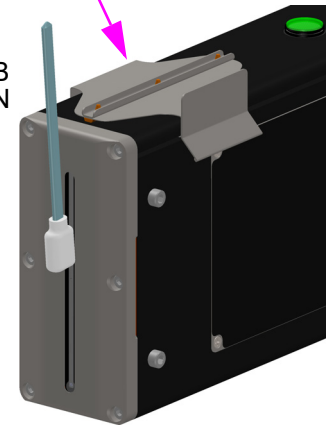

CLEAN / PRIME BUTTON

Ink Supply Module Maintenance

Daily / Shift Startup / Periodic

1. Do not remove the ink cartridge. Use a low pressure air nozzle (5psi) and / or maintenance spray and a lint free cloth to remove debris buildup on and around the Ink Supply Module.
2. Remove the cartridge from the Ink Supply Module and carefully use a foam swab to wipe out the receiver / needle area to remove any debris or ink residue.



NOTE: Do not use Maintenance Spray directly in this area.

Printer System Shutdown

Shutdowns of 1 Week or More

1. Repeat the steps in “Printer Module Maintenance” on page 20.
2. Install shipping cap onto the front of the PM and the shipping plugs into the cartridge receiver and vent on the ISM.
3. Disconnect power from the mains power cord.

Startup:

Follow instructions in “Step 8: Priming the Print Head and Testing Print Quality” on page 15.

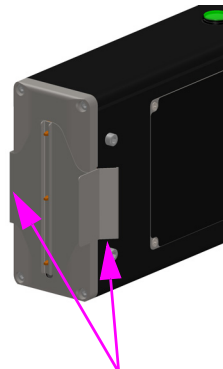

Shipping Cap -
Ensure Tabs Are Fully Seated In Slots

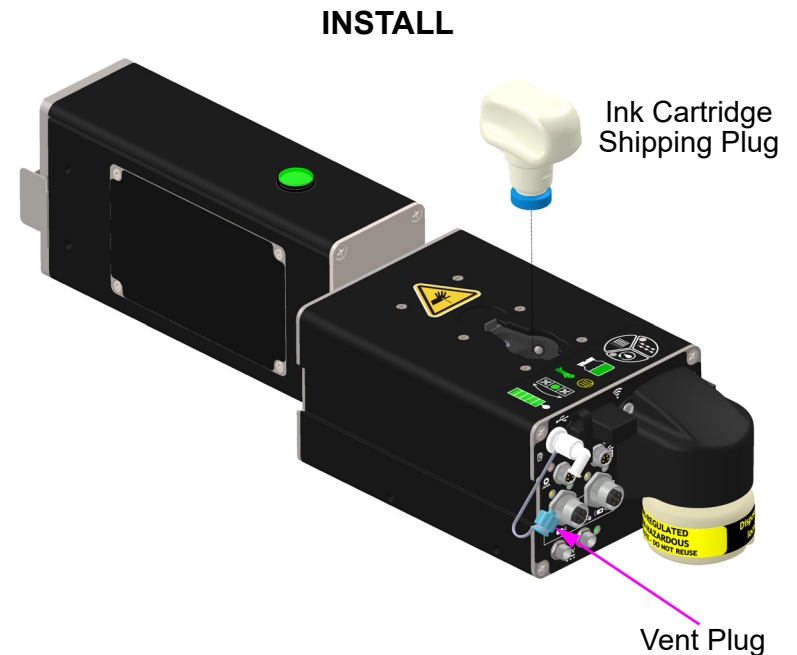

Cleaning Maintenance System

The cleaning system is an invaluable maintenance tool for routine cleaning of loose debris from the print engine orifice plate. The images below demonstrate print before and after the cleaning.



BEFORE



AFTER

Functional Description: When activated, the Cleaning System initiates with a vacuum pump, and within 2 seconds, an ink pump turns ON and flushes ink out of the orifice plate nozzles. The flow of ink captures debris on the orifice plate and flushes it down to a vacuum channel. The debris and ink mix (waste ink) is pulled back through a vacuum line into a waste bottle.



NOTE: If the LED on the top of the print head is flashing, or the Waste Full LED is red, then the cleaning system will not activate. Make sure all ink faults are corrected before attempting a cleaning cycle.

1. The cleaning feature can be accomplished by two methods.

Manually: From the rear of the print head: Press the **Clean / Prime** button. The cleaning cycle will initiate.

Automatically: By default, the print head is programmed to run a cleaning cycle every 4 hours. To change the timing, consult Create & Control manual 400463.

2. Once a print head has been cleaned, verify that all channels are printing properly by touching the **All Channel Print** button located on the back of the print head. Swipe a sheet of paper or other material across the front of the print head as the head purges. The print head fires all channels for three seconds each time the **All Channel Print** button is touched.
3. Automatically, from the controller **Clean** menu: The system can also be programmed to automatically clean the print heads during regular down times in the production schedule in increments of 30 minutes, or on a weekly schedule.

Printer Module Replacement

The normal life of a high-resolution piezoelectric printer is dictated by the amount of debris the orifice plate encounters during the coding application. Fine corrugate will fly into the orifice holes and clog / disrupt printing. Diagraph leverages the remanufacturability of its high-resolution technology by making it easy to remove the Printer Module on-the-fly and live (no need to disconnect ink or electrical lines). The Printer Module can be returned to the factory and disassembled, cleaned (down to the engine level), and returned to normal service making it more economical and green for the environment.

Printer Module swap is easy. Installation is the reverse of the below removal steps.

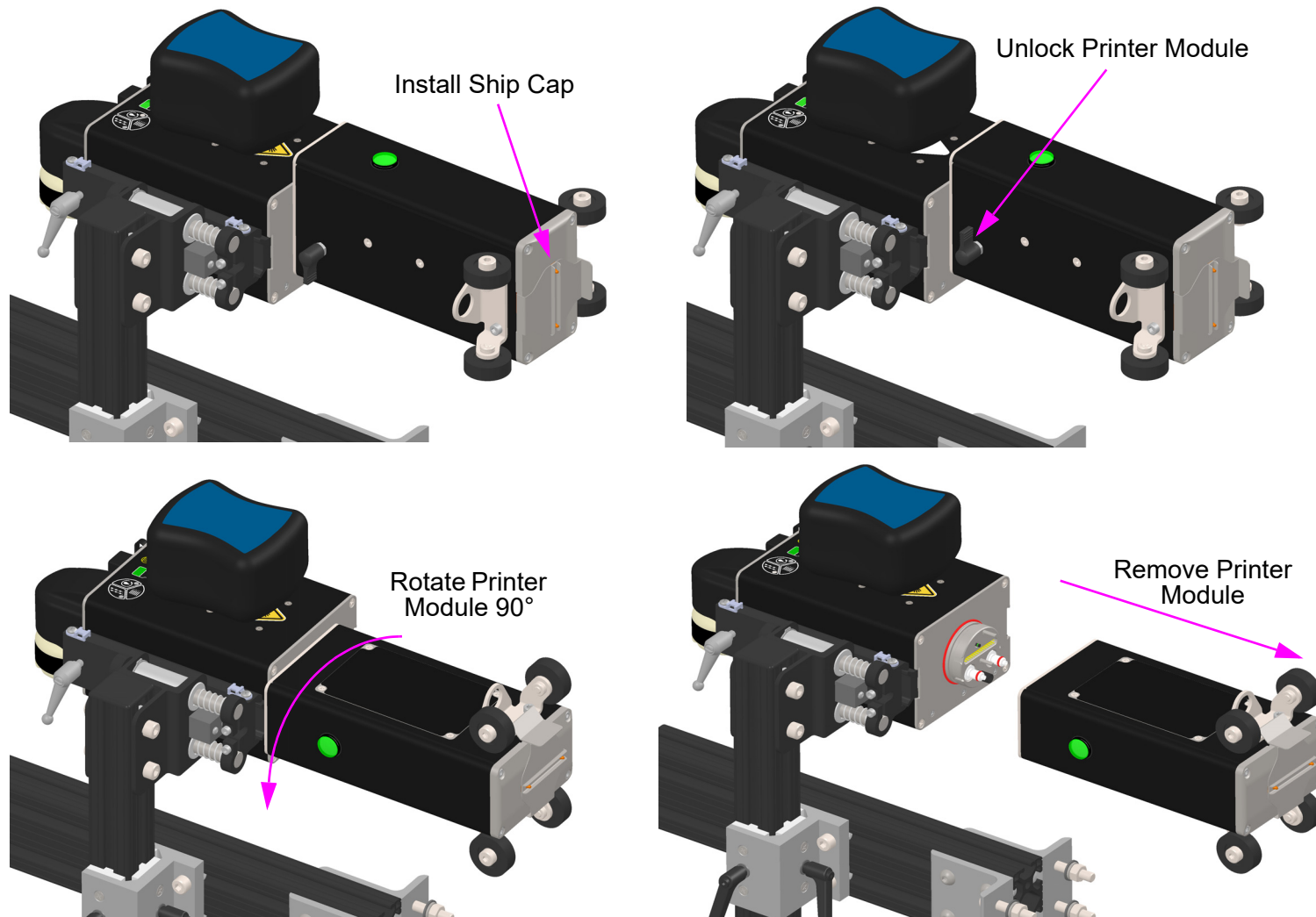

Section 4: Troubleshooting

The ResMark 5000 ink jet system incorporates advanced designs, both in hardware and in software. However, if the system ever fails to perform properly, some built-in indicators will help in troubleshooting. This section will help minimize system downtime and explain some of the diagnostic features built into the system.

Print Quality

This section shows examples of various print problems and actions which should be taken to improve the print.

Problem: Minor fractures in print channels.

Possible Cause: Debris on front plate, air in channel.

Action: Run Cleaning System, using a foam swab to assist in removal of debris.



Problem: Missing Channels and Channel fractures in print channels.

Possible Cause: Excessive debris on front plate, air in channel.

Action: Wipe front plate and run Cleaning System, using a foam swab to assist in removal of debris. Install shipping cap and activate the recirculation feature for a minimum of 2 minutes. Decap and swab the orifice plate. Prime the engine and repeat print sample.



Problem: Missing print channels.

Possible Cause: Ink weeping.

Action: Run Cleaning System. If air cannot be removed by running a cleaning cycle, run a Prime Cycle per instructions in (Cross-Reference). Perform a recirculation cycle, if necessary.



ResMark 5000 High-Resolution

Problem: Missing bottom print channels.

Possible Cause: Ink build-up on lower orifices.

Action: Check front to back level of print head.

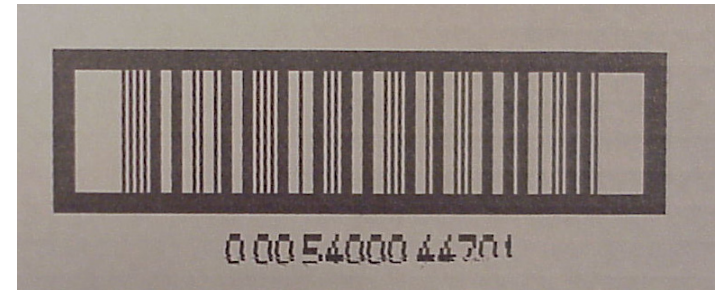

Problem: Fuzzy Print.

Possible Cause: Print head too far away from substrate.

Action: Move print head to within 1/8" from product.

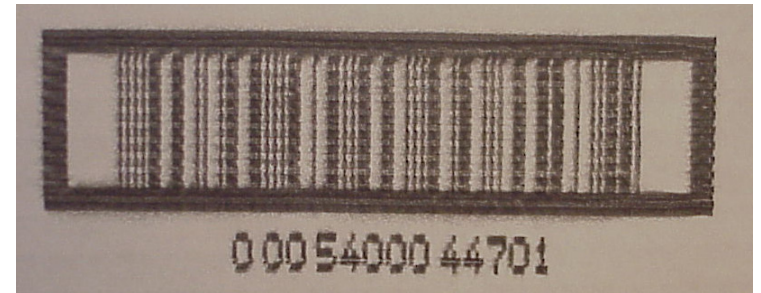

Problem: Occasional checkerboard print pattern.

Possible Cause: Encoder slipping or bouncing on belt.

Action: Tighten encoder on belt; replace encoder o-rings, if required; replace conveyor belt with smooth seamless type belt.



Problem: Stretched out, light print, checkerboard pattern.

Possible Cause: Incorrect encoder, or incorrect line speed (set too low) if using internal encoder.

Action: Check for correct encoder (must use part # 400206).

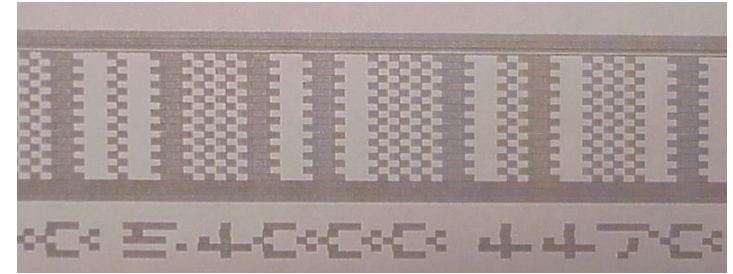

Problem: Short image, dark print, checkerboard pattern.

Possible Cause: Incorrect encoder or wheel size, or incorrect line speed (set too high) if using internal encoder.

Action: Check for correct encoder (must use part # 400206).

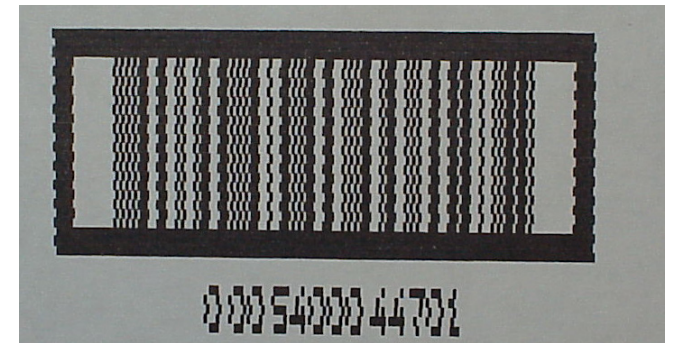

Problem: Backwards print.

Possible Cause: Incorrect print direction specified in set-up.

Action: Re-do print head set-up to specify correct direction.

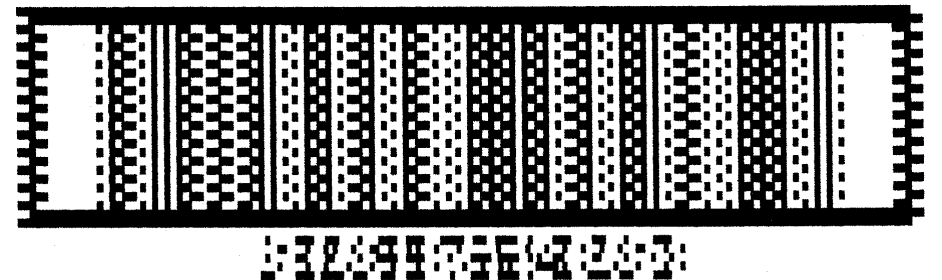

System

System Symptom	Possible Cause	Review	Observation	Action
General Power and functionality issues (Membrane LEDs abnormal or not illuminated, buttons don't function)	Power Supply	Check for Power LED to the Ink Supply Module. If LED is not illuminated, check power supply LED and / or barrel output.	No power from power supply	Replace power supply
	Power Jumper Cable	Exterior LED 6 of secondary print head OFF - disconnect power jumper cable and measure voltage	24 VDC	See PCB Board exterior test
			OFF	Replace power jumper cable
	PC Board (exterior)	Exterior LED 6	ON	Disconnect power from print head and remove rear plate-PCB assembly
			OFF	Replace PCB
	PCB Board (interior)	Insulate PCB assembly from surrounding metal objects. Connect power. Interior LED 14 heartbeat.	ON	Unlock J12, re-seat ribbon cable and engage lock
			OFF	Replace PCB
	Ink pump not working during Clean / Prime cycle	PC Board	LED11: Green; indicates a print head is signaling for the Liquid Pump to turn on.	ON
OFF				Replace PCB
Air in System		Clean both orifice plate and ship cap seal with approved sponge swab, install PM shipping cap (properly seat in grooves), and run Recirculation system for 15 minutes, decap, and run Prime cycle.	Ink flows	Check All Channel Print. If all channels are not present, repeat Recirculation as necessary
			Ink does not flow	Internal issue; run PCB board test
Waste Full		Waste LED is red. Remove waste bottle; LED should change to green.	Green	Empty waste bottle
			Red	Check internal connections to of LED array / membrane switch and re-seat J12 connector or replace PCB

System Symptom	Possible Cause	Review	Observation	Action
No vacuum at Print Head during Clean / Prime Cycle. Ink is overflowing the Print Head	PC Board	LED8: Green; indicates a print head is signaling for the Vacuum Pump to turn on.	ON	Replace Ink Supply Module
			OFF	Replace PCB
	Waste Full	Waste LED is red. Remove waste bottle; LED should change to green.	Green	Empty waste bottle
			Red	Check internal connections to of LED array / membrane switch and re-seat J12 connector or replace PCB
	Clog	Clean orifice plate and ship cap. Hold Prime button for 5 seconds and listen to vacuum pump.	Vacuum pump turns on and sounds strained, but ink slightly overflows or completely overflows.	Separate ISM / PM, remove ink waste bottle, insert rubber tipped air nozzle into vacuum port on PM. Ensure the front of the PM is covered with adequate clean cloths and apply 20psi until clear. Repeat for ISM.
Vacuum Loss	Clean orifice plate and ship cap. Hold Prime button for 5 seconds and listen to vacuum pump.	Vacuum pump turns on and sounds normal, but ink overflows or completely overflows.	Ensure waste bottle o-ring is installed and not damaged. Ensure waste bottle is installed and tight. If waste bottle is normal replace PCB or ISM.	
Print Head never reaches temp / "At Temperature" LED on membrane never turns ON	Ambient Too Cold	Measure ambient temperature with appropriately calibrated device.	Less than 4°C (40°F)	Consult factory technical support.
	Printer Module	Membrane At-Temperature and Heater LEDs	At-Temp Red and Heater always OFF	Swap Printer Module
	Ink Supply Module	Printer module swap did not fix		Replace Ink Supply Module
Missing print	Air in Print Head	Clean both orifice plate and ship cap seal with approved sponge swab, install PM shipping cap (properly seat in grooves), and run Recirculation system for 15 minutes, decap, and run Prime cycle. Perform All Channel Print.	Channels recovered	Store ship cap
			Some channels still missing	Swab clean orifice plate and repeat Recirculation
	Channels clogged or contaminated	Clean orifice plate with approved sponge swab, use prime feature, and perform All Channel Print button on clean white paper.	Print is fractured or very scratchy	Return Printer Module for cleaning
Print Head will not print at all	PC Board	Clean orifice plate with approved sponge swab, use prime feature, and perform All Channel Print button on clean white paper.	No audible or visible channel firing	Replace PCB
	Printer Module		Replacing PCB does not fix the issue	Replace Printer Module

Photosensor

Normal operation:

- Photosensor plugged into the Primary print head.
- The photosensor green power on LED is illuminated.
- The photosensor yellow detect LED illuminates when an object is held between 5 mm - 100 mm (0.2 in - 4 in) from the face of the sensor.

Do the following test to determine if the photosensor operates correctly for the application.

1. Place a representative object between 5 mm - 100 mm (0.2 in - 4 in) in front of photosensor; photosensor should sense object.
2. Place object on far guide rail; photosensor should not sense object.
3. Check that objects on the far side of conveyor do not trip the photosensor.
4. Check that color differences in product do not cause multiple photosensor trips at the farthest sensing distance.



NOTE: The test object should be a sample of the actual product.

NOTE: If the green power LED or yellow LED on the photosensor fails to illuminate when an object is placed in front of the photosensor, it indicates that the photosensor and / or power supply is disconnected, or the power supply, CPU, or photosensor has failed.

Encoder

Ensure the encoder is plugged into the Primary print head.

Navigate to the NextControl status screen. If the line speed displays a value comparable to the known line speed, then the encoder is functioning correctly. If the line speed displays "0", then check electrical connections to the encoder and PCB. Refer to **Create & Control manual 400463**.

Appendix A: System Specifications

System

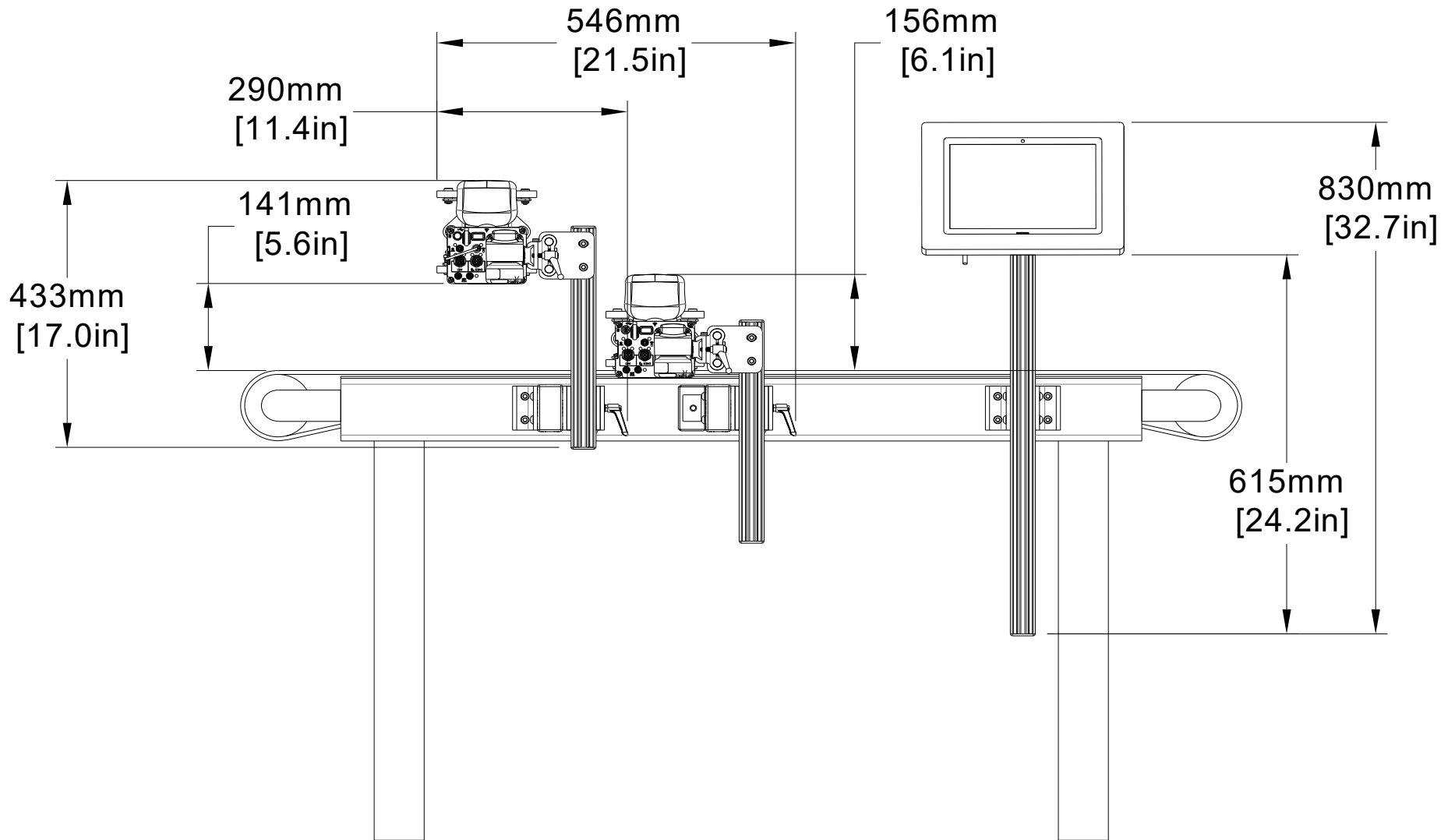

Touch Pro 2 HMI

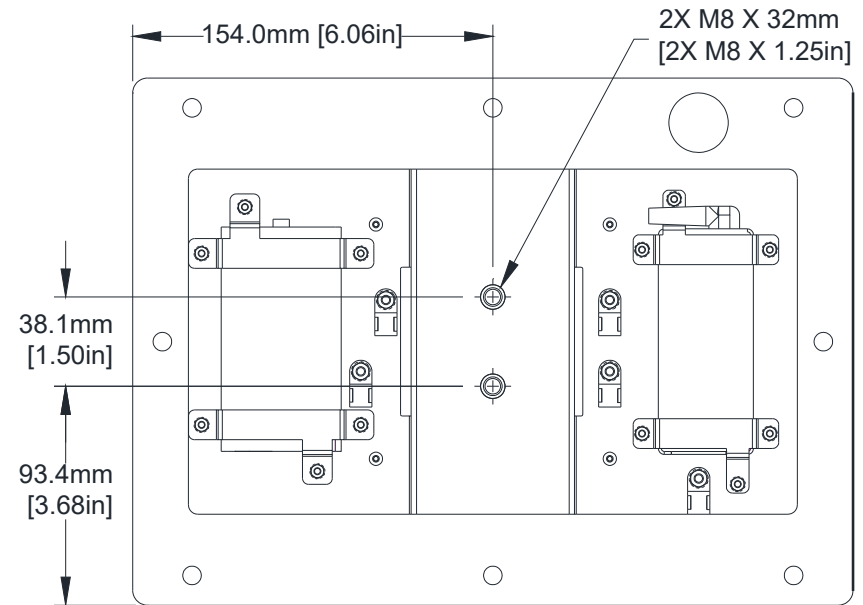
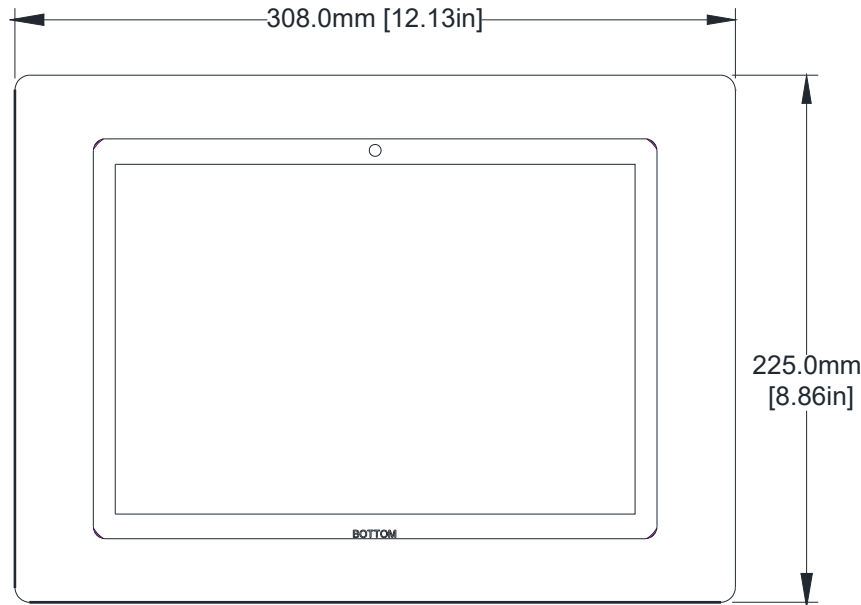

Size

Weight: 2,18kg [5.5lb]
Height: 196,1mm [7.72in]
Width: 330,7mm [13.02in]
Depth: 41,3mm [1.62in]

IP Rating

IP34 (estimated)

Enclosure

HDPE Plastic

User Interface

Graphical User Interface
with on screen keyboard

Fonts

True Type

Display

274.3mm [10.5in] LCD with TFT touch
screen, 1920 X 1280 pixels

Storage & Memory

64GB SSD
4GB RAM

Ports

(2) USB-A 3.0 port
(1) Gigabit Ethernet port

Electrical

Input: 12VDC, 3A

Environment

Ambient operating temperature: 0°C - 40°C
(32°F to 104°F)

Operating humidity: 10% - 90%, non con-
densing

Mark 2 Print Head

Size - Mark 2 Head

L: 447mm [17.6in]
 W: 66mm [2.6in]
 H: 117mm [4.6in]
 Weight: 2,7kg [6lbs]

IP Rating

IP65 (estimated)

Enclosure

Anodized aluminum, black

Electrical

24VDC, 2A input

Filtration

75 micron ink supply vent filter

Print Speed

Alpha/Numeric Text: Up to 61 meters per minute [200 feet per minute] @ 200 dpi; 40 meters per minute [130 feet per minute] @ 300 dpi.

Barcode: Up to 46 meters per minute [150 feet per minute] @ 200 dpi.

* Higher line speeds achievable with reduction of dpi.

Print Resolution

384/128 Engine: 128 addressable channels, 51mm [2in] solid print height

Throw Distance (Print Gap)

Up to 6,4mm [1/4in] for alphanumeric. 3,2mm [1/8in] recommended for best barcode quality.

Ink Type

ScanMark, Pigmented Ink for porous substrates, black

Environment

Ambient operating temperature: 4°C to 40°C (40°F to 104°F)

Operating humidity: 5% - 90% non-condensing

Cleaning System Consumable Usage

ScanMark Ink: 0.6ml

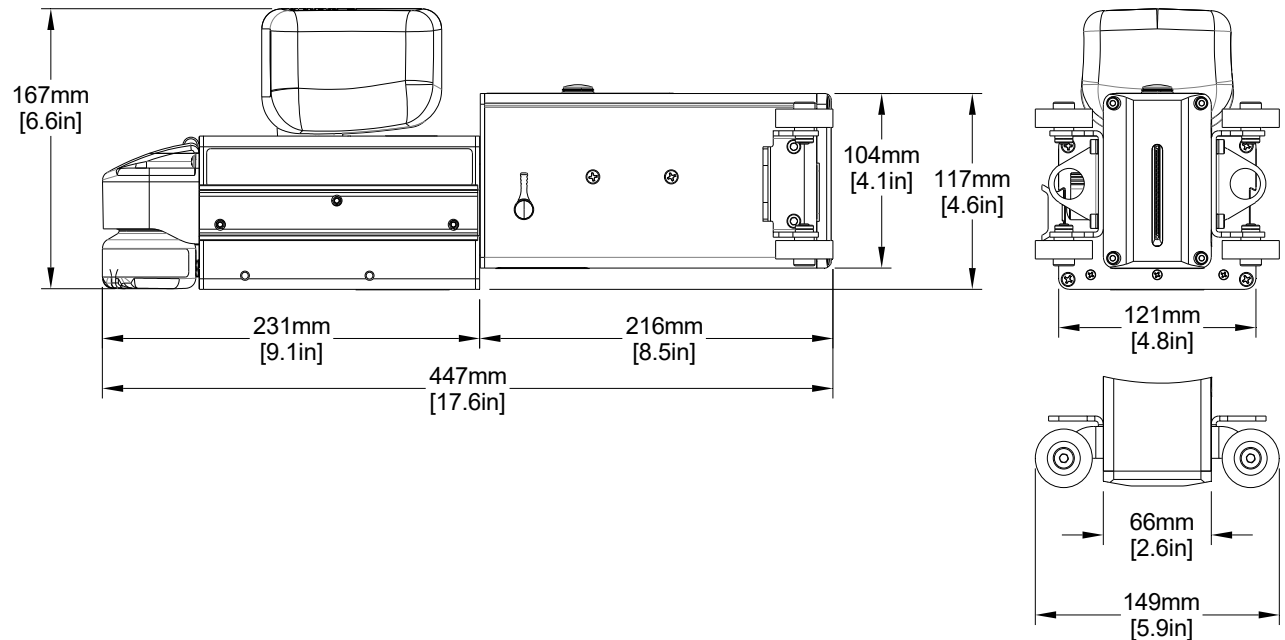

Print Swath and Tilt

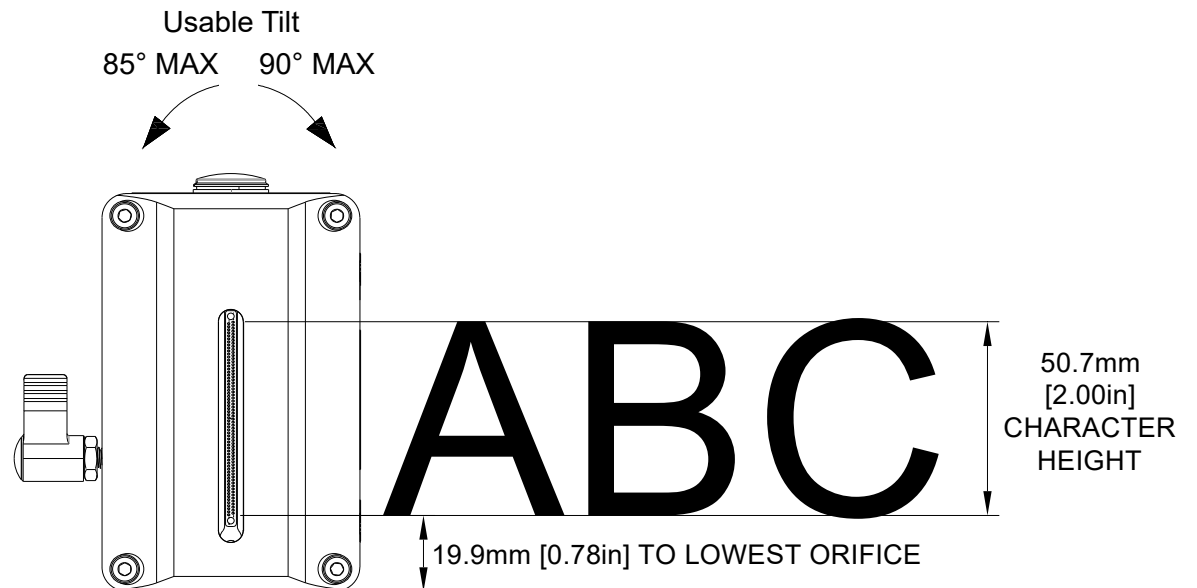

Mark 4 Print Head

Size - Mark 4 Head

L: 338,1mm [13.31in]
 W: 71,1mm [2.80in]
 H: 160,8mm [6.33in]
 Weight: 4,3kg [9.5lbs]

IP Rating

IP65 (estimated)

Enclosure

Anodized aluminum, black

Electrical

24VDC, 2A input

Filtration

75 micron ink supply vent filter

Print Speed

Alpha/Numeric Text: Up to 61 meters per minute [200 feet per minute] @ 200 dpi; 40 meters per minute [130 feet per minute] @ 300 dpi.

Barcode: Up to 46 meters per minute [150 feet per minute] @ 200 dpi.

* Higher line speeds achievable with reduction of dpi.

Print Resolution

768/256 Engine: 256 addressable channels, 102mm [4n] solid print height

Throw Distance (Print Gap)

Up to 6,4mm [1/4in] for alphanumeric. 3,2mm [1/8in] recommended for best barcode quality.

Ink Type

ScanMark, Pigmented Ink for porous substrates, black

Environment

Ambient operating temperature: 4°C to 40°C (40°F to 104°F)
 Operating humidity: 5% - 90% non-condensing

Cleaning System Consumable Usage

ScanMark Ink: 0.7ml

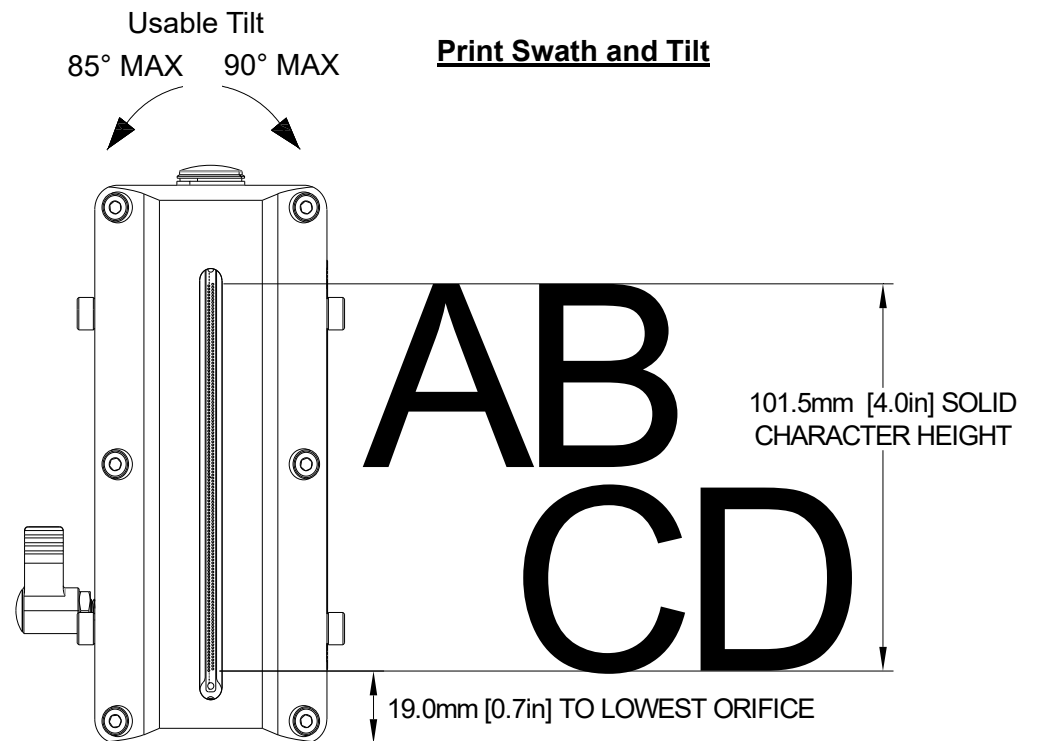
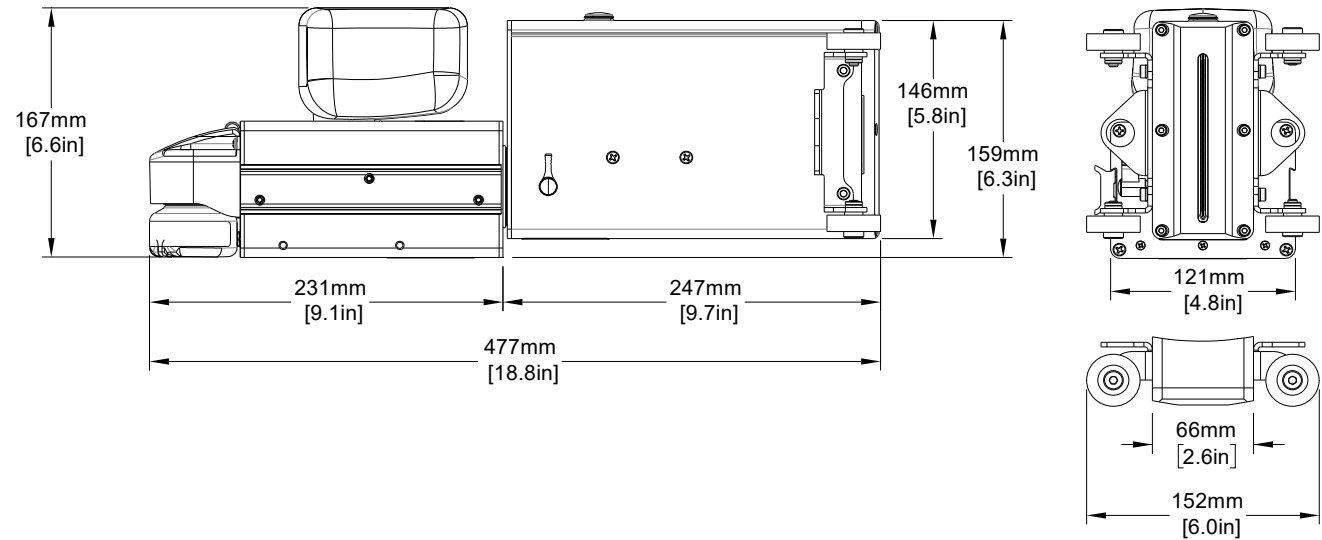

System Interconnect Diagram

1. Mark 4 Print Head
2. Mark 2 Print Head
3. HMI
4. Conveyor
5. Product and Print Direction
6. Print Head Bracketry
7. Ink Status / Communications LED
8. Encoder
9. Photosensor
10. Encoder Cable
11. Photosensor Cable
12. Ethernet Cable, HMI to Print Head
13. Ethernet Cable, Print Head to Print Head
14. Throw Distance (1mm - 2mm [.04in - .08in] Recommended)

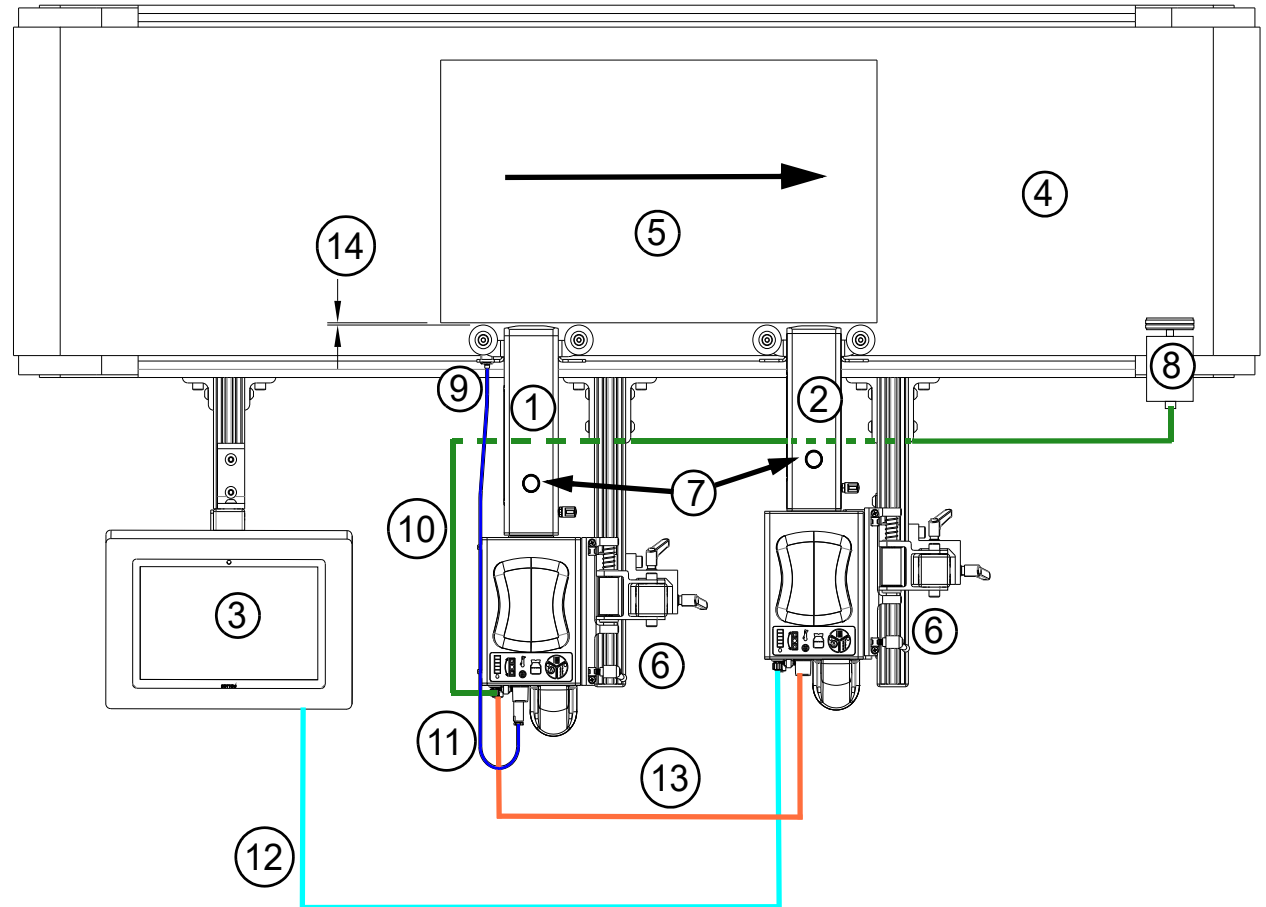

Customer System Connection

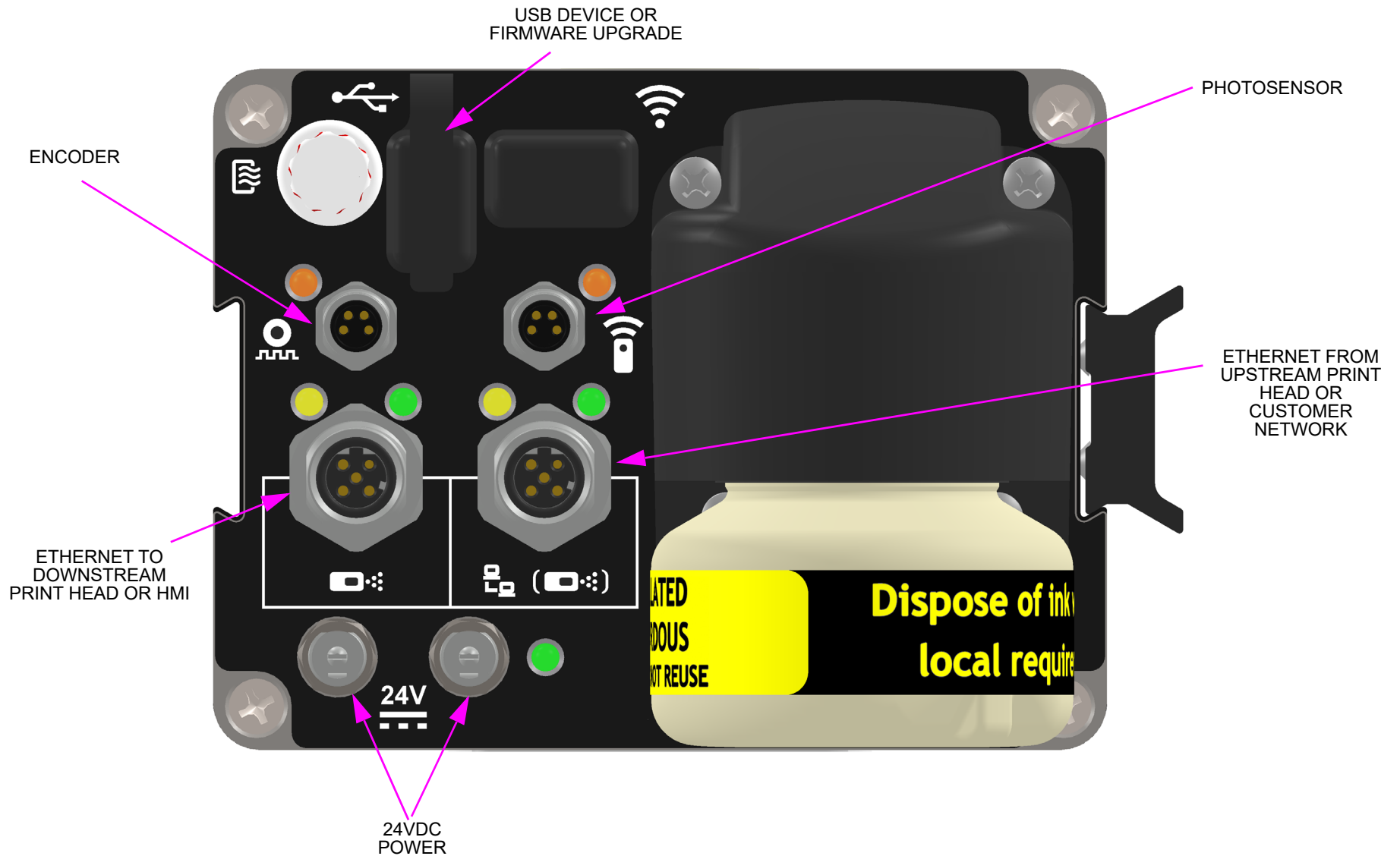

Appendix B: Theory of Operation

Functional Description

The ResMark 5000 high-resolution ink jet system prints text, autocodes (such as product counts or time and date stamps), barcodes, and/or graphics onto products as they travel by conveyor past stationary print heads. Print can be placed on any one of, or a combination of, the product's sides. The conveyor speed is monitored using a variable speed encoder or a built-in fixed speed encoder. Products are detected using a photosensor. The information to be printed is defined as a message whose elements are created and controlled in software and maintained on the ResMark Ink Supply Module.

ResMark 5000 Mark 2 and Mark 4 Print System

The ResMark 5000 print system consists of an Ink Supply Module (ISM) and Printer Module (PM). The ISM is comprised of a Smart CPU printed circuit board, ink cartridge, ink manifold, ink pump, vacuum waste system, and male coupling. The PM contains a female receiver coupling, ink management fluidics, and piezoelectric print engine.

Ink Supply Module (ISM)

Ink flow and pressure is managed by the ISM along with ink waste recovery. When the ink cartridge is inserted into the septum receiver, two needles puncture the septum on the cartridge and allow for ink to flow into the manifold up to a control point level. Atmospheric pressure is allowed through a vent on the rear of the ISM. When the system is printing, capillary action pulls the ink from the ISM into the PM, and to the piezoelectric print engine. The action of ink flow from printing or priming lowers the ink level in the manifold reservoir to the control point where atmospheric pressure allows the flow of ink from the cartridge. In addition to ink flow, the ISM manages ink recirculation and priming via an ink pump. When either the **Recirculation** or **Clean / Prime** feature buttons are activated, the ink and vacuum pumps turn ON, and the print is disabled. During **Recirculation**, the ship cap should be installed. When using the recirculation feature, downstream pressure builds allowing optimal conditions for removing unwanted air from the ink supply system and wetting of the print engine ink pathways. Finally, the ISM provides a means of ink / waste collection from the use of the **Clean / Prime** feature.

The ISM CPU electronics control all functionality of the printer system. These functions include all fluidic management, LED's, button presses, wireless and wired connectivity, photosensor and encoder communication, message storage, and all print imaging features. Once a message has been sent to the printer and requested to print, external HMI / controller connectivity is not necessary (i.e. Smart Print Head).

Printer Module (PM)

The fluidics in the PM appropriately manage ink as it enters and exits the ink ports of the print engine. When the system is placed in **Recirculation** mode, with the ship cap installed, ink pressure and flow from the ISM through the PM moves air bubbles back to the ISM and is ventilated from the system.

The piezoelectric inkjet print engine has a nozzle plate with an array of orifices and a corresponding array of piezoelectric crystals. These crystals expand and contract rapidly based on voltage being supplied to them. Very small ink pulse waves are created as a result of piezoelectric crystals expanding rapidly, creating a pressure pulse to force ink droplets out the orifices. The print engine also incorporates a heater to control the head temperature, allowing ink viscosity to be maintained over a wide spread of ambient temperatures. The print engine must be at the correct operating temperature before printing and can be monitored via the LEDs located on the rear of the ISM. They show when the heater is ON (irregular modulation) and when the print engine is at the appropriate temperature (steady ON light).



NOTE: Since ink is fed to the print engine via gravity, it is important to maintain the print head at a level position during operation.

ISM Features

Recirculation

This feature can only be controlled locally at the print head as the orifice shipping cap must be aligned properly and securely mounted in place. Recirculation is a unique and valuable feature as channel priming time is reduced at initial setup, or channel loss due to significant vibration and / or high-impact events. The feature can be activated by pressing and holding the **Recirculation** button on the top of the ISM for 10 seconds; its LED turns ON as shown. During this time it is critical to have the orifice shipping cap installed and properly aligned with the supplied front-plate grooves. The user can choose when to disengage the feature by manually pressing the button again, or it will time-out after 15 minutes. After removing the ship cap and swabbing the orifice plate, the prime feature should only be needed 1-2 times, significantly reducing the amount of ink usage. In addition, the expectation should be for significant channel recovery.

Clean / Prime

The print system also incorporates a Cleaning System to remove debris from the orifice plate. A small vacuum channel has been designed into the bottom of the nozzle plate.

During a cleaning cycle, a small amount of ink is pulsed through the orifices. When the cleaning cycle is activated, the vacuum pump turns ON, as well as its LED (shown OFF), shortly after, the ink pump pulses to control the flow out of the nozzle plate, and then the vacuum pump continues to run for 45 seconds to ensure ink / waste residue is pulled to the waste collection bottle located at the rear of the ISM. A Clean cycle can be manually initiated by pushing the **Clean / Prime** button located on the rear of the ISM, or it can also be programmed to run at specified times by using the control software.

All Channel Print

The functionality to check for 100% print from the print head is available locally at the print head. This function can be performed by momentarily pressing the **All Channel Print** button on the rear of the print head while passing a substrate in front of it in a horizontal direction.

PM Digital Level

A digital level indication is provided by three LEDs located on the top rear of the enclosure. The print head is considered level, as indicated by a central green LED, when the PM is within +/- 1.5° front-to-back, level to the horizon. The digital level is factory calibrated.

Ink Cartridge Status Gauge

Ink volume in any given cartridge is tracked down to the milliliter. Status is both read and written to the cartridge. If the cartridge is moved to another print head, then the correct ink volume is maintained with the cartridge. In addition, there are five LED divisions on the rear of the ISM. Each division representing 20% ink volume.

Waste Bottle Status

During normal operation the waste bottle status light will be green; indicating the waste bottle is not full. When the ink waste level rises to a point where it lifts the float UP in the waste module, this LED will turn red. The waste ink will then need to be removed and emptied according to local laws and regulations. When the waste bottle is removed, the float switch will drop DOWN, and the LED will change to green.

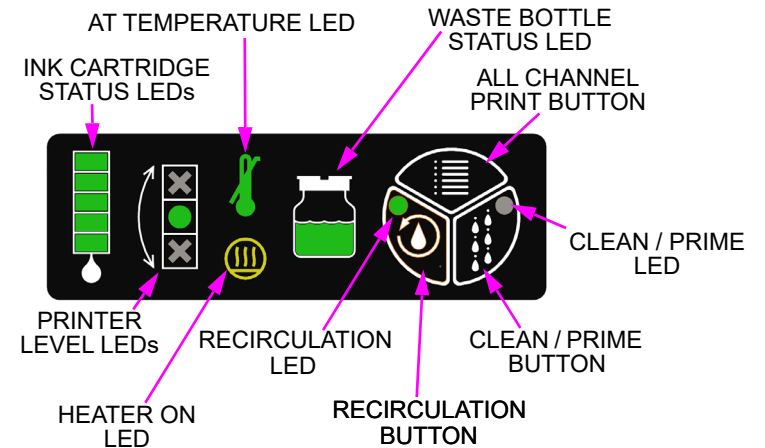

Ink States

Normal Operation

During Normal Operation, the Primary LED on top of the PM is illuminated green because there is at least 20% or more ink left in the cartridge, and the smart chip on the cartridge is being read properly. Print is always enabled in Normal Operation.



Ink Low

When there is less than 20% ink left in the cartridge, the lowest two LED's on the ink supply gauge are yellow and red from top to bottom alerting the user that Ink Out is imminent. Also, the Primary LED changes to red. Print does not disable.



Ink Out

When **100% of all the ink has deposited from the cartridge** and into the ISM reservoir, the ink level begins to drop. At a controlled point, the float in the reservoir drops low and triggers the Ink Out state. The lowest LED on the ink gauge changes to flashing red as does the Primary LED. For best practices, **this is the appropriate time to change the ink cartridge**. The time to refill the reservoir with a new cartridge is minimal. Print does not disable.



Ink Error (Faults)

1. If the Ink Out state is ignored, a buffer is in place to allow for additional printing. Ten more milliliters of ink are allowed. The time to consume this volume is variable based on application parameters. Once this 10ml volume is consumed the system will change to an Ink Error state. The LED's on the ink gauge will fast flash as will the red primary LED. In addition, print will be disabled. It will take approximately 30 seconds to refill the reservoir and lift the float switch up. At this point, print will be enabled.
2. If the ink cartridge is removed, then the operator will have 15 minutes to replace the cartridge. After this time is expired, and the cartridge has not been replaced, then print will be disabled, and all LEDs will flash on the ISM interface.
3. If an incorrect cartridge type is inserted, then print will immediately be disabled and all LEDs will flash on the ISM interface.



NOTE: Never mix ink types because they are not miscible. Irreversible internal damage will occur.

Ink Waste Collector Full

Upon filling the ink waste collector bottle, a float level detect raises inside the separator assembly. The feature disables pumps inside the ISM until the waste bottle is emptied. By disabling the pumps, overflow is prevented at the separator bottle. If the waste bottle is filled (waste float up) during a Clean / Prime, the cycle will complete; however, subsequent cycles are not allowed.



Print Head Daisy Chain

Print heads attach to the system (production line) in a daisy chain configuration via Ethernet or wireless. The Primary print head is the beginning of the daisy chain and has the photosensor plugged into it. All data is fed downstream from the primary print head to the daisy-chained heads.

If connecting the system via hard cables, an Ethernet cable can be connected from the HMI / Controller to the Primary print head CPU (J6). The next downstream head will connect to the Primary head via an Ethernet cable between the output port (J7), and the input CPU port (J6) on the next print head. This I/O repeats for all downstream heads. The maximum number of daisy chain print heads is eight.

One power supply can power up to two print heads and an HMI, independent of printer size (Mark 2 or Mark 4). An additional power supply is required for every two print heads in the daisy chain.

When print messages are sent to the Primary print head, all downstream daisy chain print heads receive the same information. When a production line is running, photocell and encoder data are dynamically communicated to all the print heads to maintain timing and stay in sync.

Print Trigger Photosensor

The photosensor detects when a product is about to pass by the PM nozzle plate and signals the CPU to start a print cycle. The photosensor signal is active low, and it must remain low for at least one encoder pulse. Once a print cycle starts, it continues to completion regardless of what the photosensor signal does.

The system is compatible with through-beam, retro-reflective, and diffused photosensors that work at 24VDC and have a current sinking (or open collector) output. The photosensor plugs into the print head CPU (J5).

Encoder

The encoder determines the time period between the printing of individual columns, or the print speed. As a product's speed increases, the time period between columns must decrease, that is, the print speed must increase, to maintain consistent column-to-column spacing. The system has two encoder options, external and internal. Use the external encoder when the conveyor speed fluctuates. Use the internal encoder when the conveyor speed is constant.

The **external encoder** is a 24VDC optical encoder. The encoder's wheel is sized such that the encoder outputs 300 pulses per inch of product travel. The external encoder plugs into the print head CPU (J4), and its signal is used to time the sending of column data to the print head.

The **internal encoder** signal is a constant frequency pulse stream generated on the print head CPU. This pulse stream is divided down in the CPU to generate the desired speed / timing.

Appendix C: Diagrams

ResMark 5000 Main CPU PCB Assembly

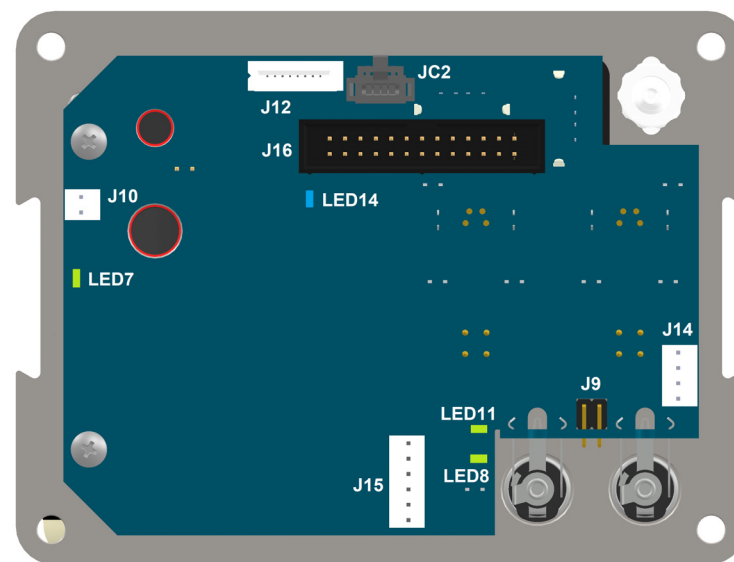

LED	Description	Connector	Description	Connector	Description
LED1	Ethernet: ON = 100 Mbps; OFF = 10Mbps	J1	WIFI Dongle: USB	J15	Ink and Vacuum Pumps: 6-pin
LED2	Ethernet: ON = 100 Mbps; OFF = 10Mbps	J2	Power: 24VDC, 3/8-32 threaded	J16	Print Engine: 26-pin
LED3	Ethernet: Flashes indicates network traffic	JC2	Smart Chip: 4-pin	J22	Optional Serial: USB-A
LED4	Ethernet: Flashes indicates network traffic	J3	Power: 24VDC, 3/8-32 threaded		
LED5	Photosensor: Indicates product detect	J4	Encoder: M8		
LED6	Power: Indicates power to ISM	J5	Photosensor: M8		
LED7	Float Switch: Indicates ink full in reservoir	J6	Ethernet Input: M12		
LED8	Vacuum Pump: Indicates ON	J7	Ethernet Output: M12		
LED9	Encoder: Indicates ON / moving	J10	Reservoir Float Switch: 2-pin		
LED11	Ink Pump: Indicates ON	J12	Membrane Switch & LED: 8-pin ZIF		
LED14	Heartbeat: Indicates program is active	J14	PM Primary LED: 4-pin		

ResMark 5000 Internal Wiring Diagram

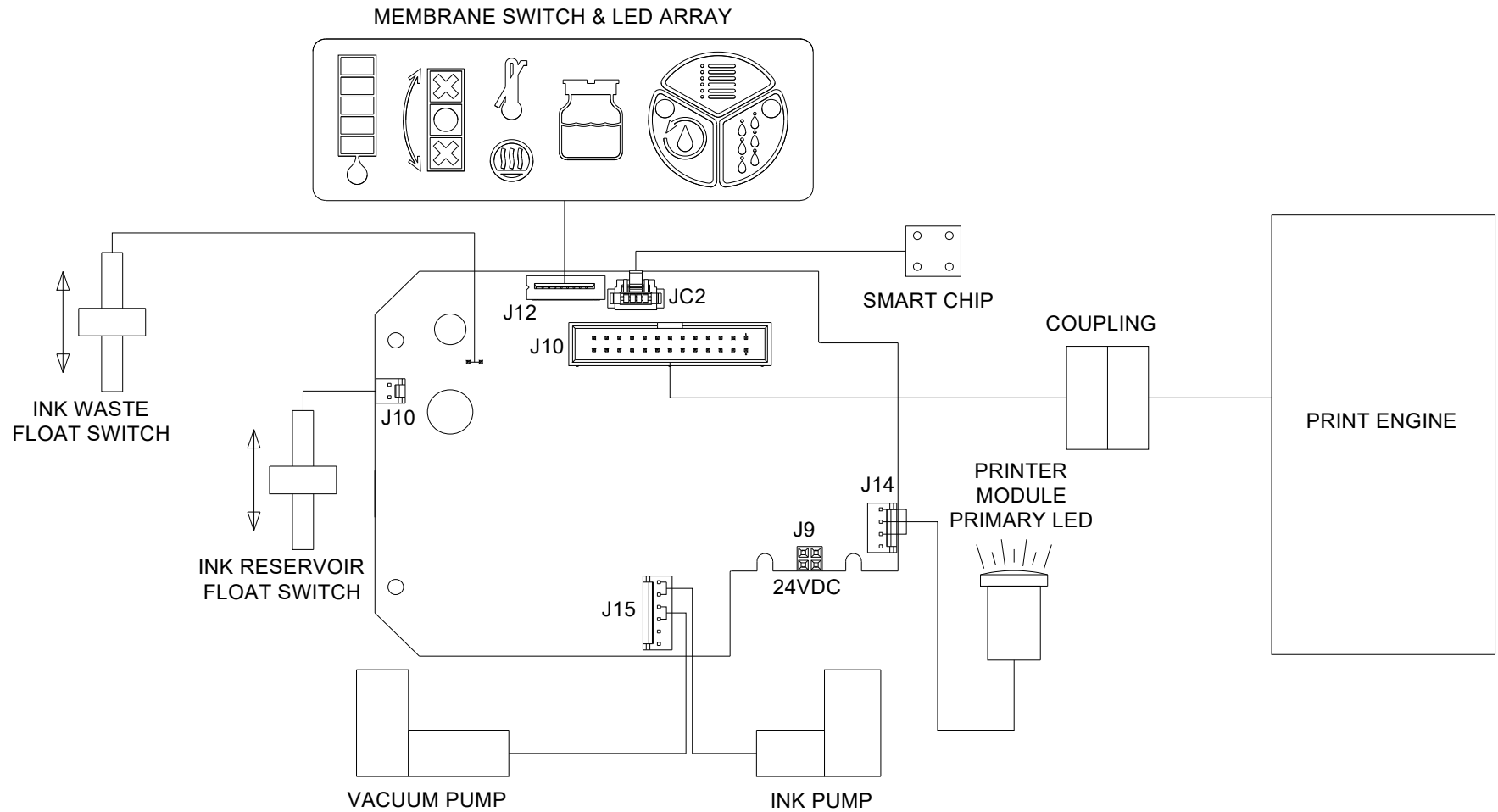

Appendix D: Ink

Storage Life of a FACTORY SEALED Bottle of Ink

- ScanMark: 24 months from date of manufacture.
- Store in a cool dry environment between 10°C - 32°C (50°F - 90°F).

Temperatures above or below the recommended storage temperature for a period greater than one week will reduce the storage life of the ink.



NOTE: Do not shake the ink cartridge before use. Agitating the ink may introduce air into the Print Head. If shaken, the bottle must sit for at least two hours before use.

Use Life of an OPENED Cartridge of Ink

- ScanMark: 3 months from opening.



NOTE: Exposure to air, temperature and relative humidity will affect the useful life of the ink.

Appendix E: Updating the ISM via USB or Ethernet

For instructions on updating the ISM, refer to **Create & Control manual, 400463**.

Appendix F: Software Interface

For information on interfacing with the software, refer to **Create & Control manual, 400463**.

Appendix G: Part Numbers

System

Item	Part No.	Description
1	404050DG	HMI / Controller
2	400001PDG	Mark 2 Print Head, ScanMark (Domestic or European)
3	400004PDG	Mark 4 Print Head, ScanMark (Domestic or European)

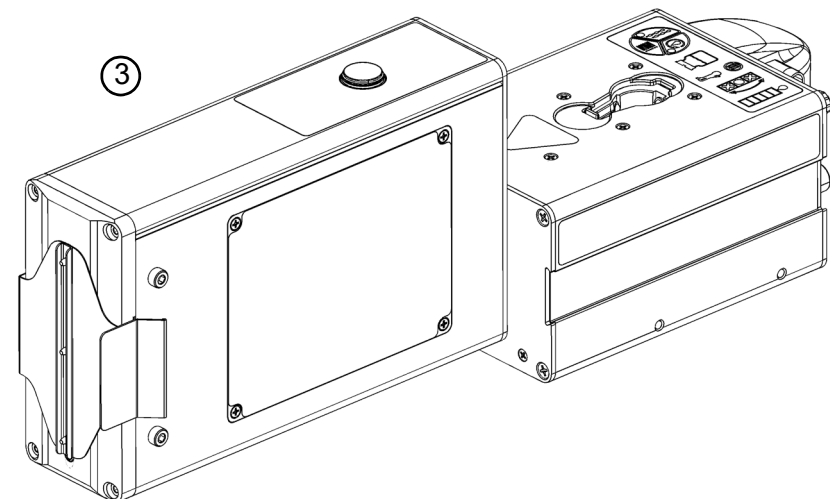
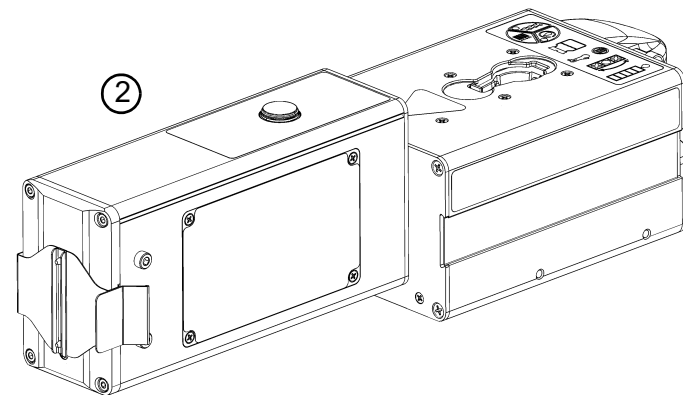
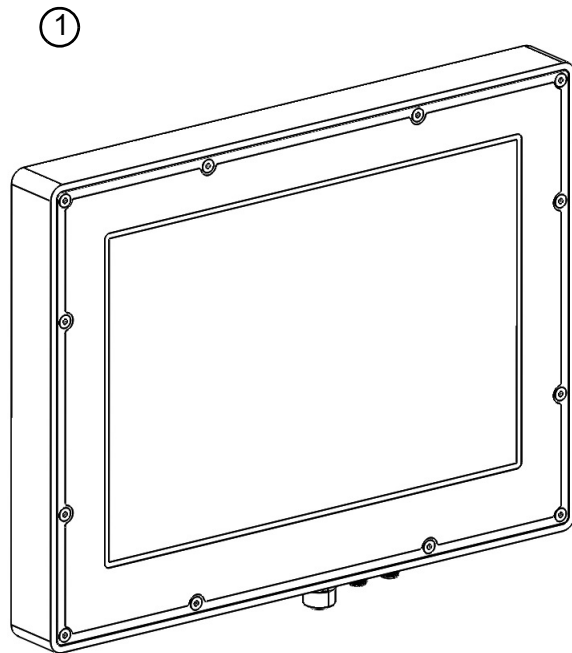

Print Head Replacement Parts

Item	Part No.	Description
1	400002PDG	Ink Supply Module, ResMark 5000, ScanMark
2	400003PDG	Printer Module, Mark 2, ScanMark (Domestic or European)
3	400005PDG	Printer Module, Mark 4, ScanMark (Domestic or European)
4	400205	PCB, Rear Plate, & Vacuum Module Assembly
5	400214	Roller with Mounting Bracketry, Mark 2
6	400215	Roller with Mounting Bracketry, Mark 4
7	5760835	Roller Replacement Kit (5 Rollers)
8	400209	Orifice Ship Cap, Mark 2
9	400210	Orifice Ship Cap, Mark 4

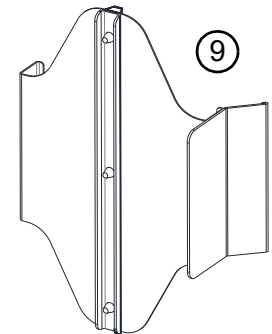
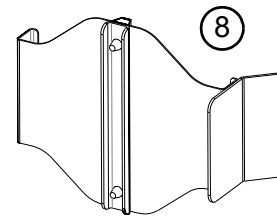
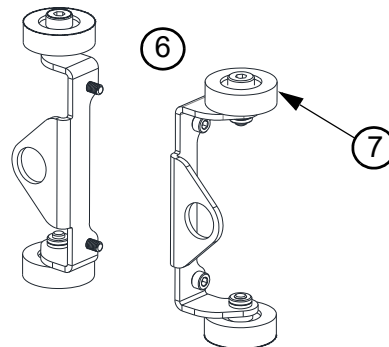
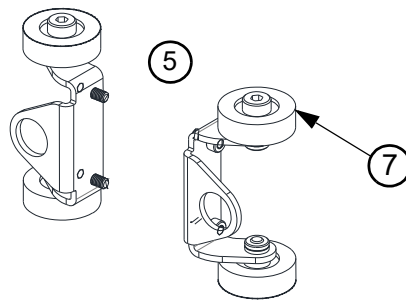
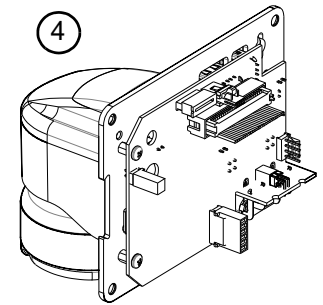
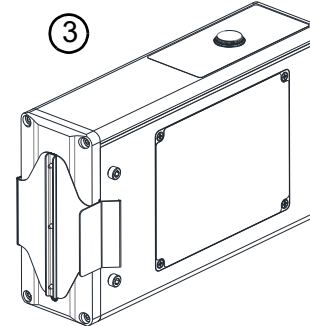
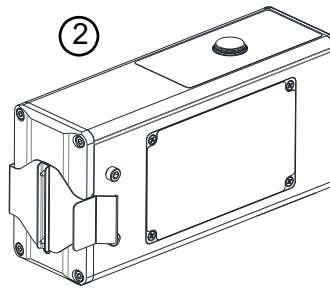
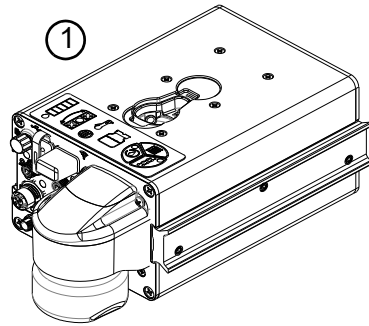

Bracketry

Item	Part No.	Description
1	400200	Mounting Bracket Kit with Retractor for Mark 2 or Mark 4 Print Head (Domestic or European)
2	400201	Mounting Bracket Kit with Retractor and Rollers for Mark 2 Print Head (Domestic or European)
3	400202	Retractor Mounting Bracket Kit
4	400204	Mounting Bracket Kit with Retractor and Rollers for Mark 4 Print Head (Domestic or European)
5	5765249	T-Base Stand Kit
6	5765250	HMI / Controller Conveyor Mounting Bracket Kit
7	5760354	Multi Print Head Conveyor Mounting Kit *
8	5760355	Print Head Floor Mounting Kit *
9	5760356	Multi Print Head Floor Mounting Kit w/24" Bar *
	5760357	Multi Print Head Floor Mounting Kit w/44" Bar *

* Requires Single Print Head Kits (400200, 400201, or 400204)

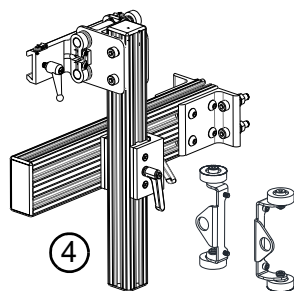
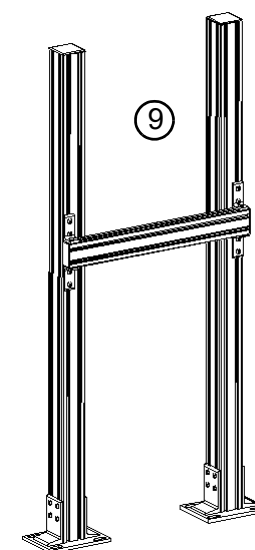
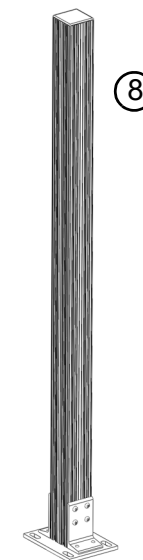
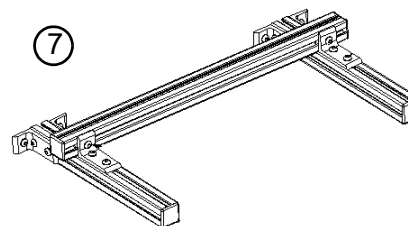
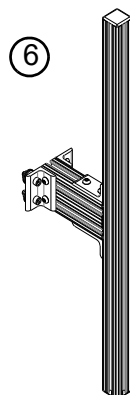
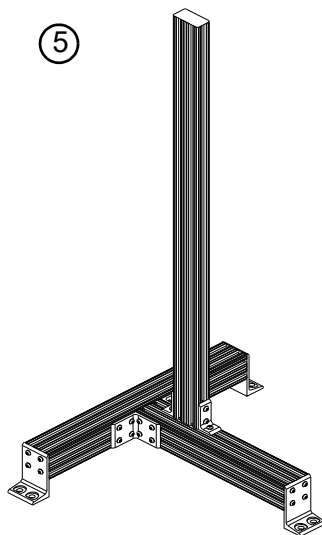
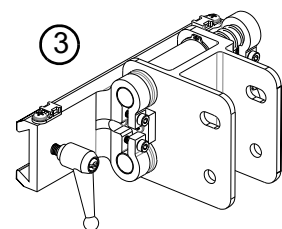
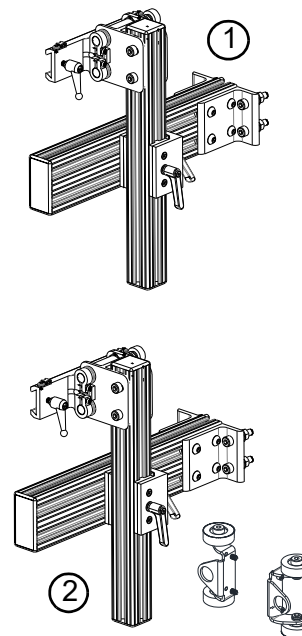

Fittings

Part No.	Description	Contents	Where Used
400223	Fitting, 400522, Luer Cap, Male	5 fittings per kit	ISM vent port - storage
400224	Fitting, 400521, Luer, 90 degree	5 fittings per kit	ISM vent port - while printing
5765241	Fitting, 5765562, Luer, 75 Micron Filter	5 fittings per kit	ISM vent port - while printing

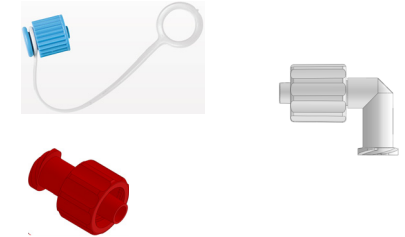

Cables

Item	Part No.	Description
1	400490-2.0	Cable, Power Jumper, 2m
2	400490-3.0	Cable, Power Jumper, 3m
3	400371-2.0	Cable, Ethernet, Print Head to Print Head, 2m
4	400371-3.0	Cable, Ethernet, Print Head to Print Head, 3m
5	400374-2.0	Cable, Ethernet, Print Head to RJ45, 2m
6	400227	RJ45 Ethernet Coupler
7	400530	Extension Cable, M8, 5m (Photosensor or Encoder)

NOTE: Other lengths available; consult the factory.

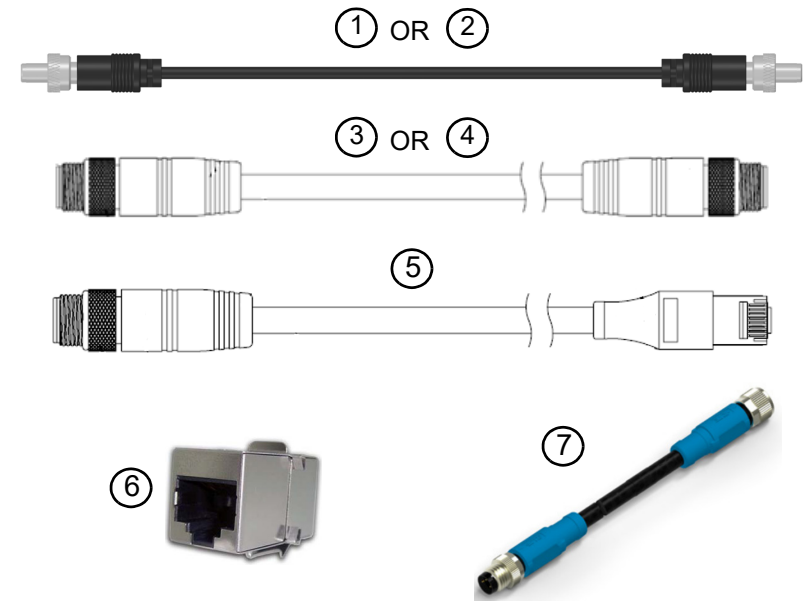

Consumables

Part No.	Description	Contents
400212DG	Ink, ScanMark, Pigmented Porous Media, Black, 2-PACK	2 Cartridge, 500mL
400213DG	Ink, ScanMark, Pigmented Porous Media, Black, 12-PACK	12 Cartridge, 500mL
5760695	High-Resolution Maintenance Spray for ScanMark	2 Pack, Spray Can
5760800	Start Up / Cleaning Kit	Gloves, Lint-Free Wipes and Foam Swabs
5760832	Sponge Swabs	100 Sponge Swabs
6600171	Lint-Free Wiping Cloths	300 Cloths

Service Parts and Optional Equipment

Item	Part No.	Description
1	400203	Photosensor, Diffuse Type w/ 2ft Cable
2	400206	Encoder Assembly w/Mounting Bracket & 25ft Cable
3	400211	Beacon, Remote
4	400216	Plug, M8 Connector, pack of 10
5	400217	Plug, M12 Connector, pack of 10
6	400218	Cap, 5/16 Power Connector, pack of 10
7	400219	Shipping Plug, Ink Supply Module
8	400220	Shipping Plug, Printer Module
9	400221	Wheel Replacement, Encoder
10	400222	Power Supply and Mounting Bracket Hardware
11	400225	Waste Bottle, pack of 6

